



# MAGNET TECHNOLOGY

CLUTCHES AND BRAKES

EN



### KEB AUTOMATION KG

All our efforts are directed towards the development, production and application of electromagnetic technology throughout our extensive range of brakes and clutches.

The functions, **starting, stopping, positioning and safe holding** of moving axes in machines and plant call for reliably designed and safely functioning components.

With our advanced manufacturing techniques we are able to produce high quality, high-grade products, and through our continued investment we now have manufacturing plants worldwide. We have the ability to produce high volume stock parts or ones that are tailored specifically to your requirements.

## SAFE BRAKING AND HOLDING

**COMBISTOP H**



**COMBISTOP D**



**COMBISTOP T**



**COMBISTOP N**

**COMBIPERM P1**



**COMBIPERM PC**



**COMBIPERM P1**



### COMBISTOP

... starting from page 4

Electromagnetically actuated dual-surface spring applied DC brakes for dry operation.

### COMBIPERM

... starting from page 16

Permanent magnet brakes and clutches for dry operation.

## SWITCHING, STOPPING, POSITIONING

**COMBINORM C**



**COMBINORM B**



### COMBINORM

... starting from page 22

electromagnetic-actuated open-circuit operated clutches and brakes without slip rings.

**COMBIBOX**

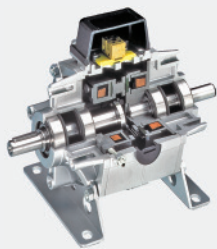

### COMBIBOX

... starting from page 34

a ready to be installed electromagnetic-actuated clutch-brake-module

## POWER SUPPLY / SWITCHGEAR

**COMBITRON 91**



**COMBITRON 98**



### COMBITRON

... starting from page 42

DC-supply from the alternating voltage supply system.

# COMBISTOP PROGRAM SCHEDULE

COMBISTOP are electromagnetically actuated dual surface spring-applied DC brakes for dry application. The braking force is applied by the springs and released through the electromagnetic force. These brakes are successfully working in the most demanding applications and are used wherever rotating masses must be stopped or shafts need to held in a precise position.

High quality materials together with high precision manufacturing, process inspections and functional testing guarantee reliable, safe operation.

On request we can design the COMBISTOP brake to your requirements, for example the brake can be supplied with pre-mounted armature and increased torque.

Please bear in mind that the rated torques are achieved after a required running-in process.

- certified to  on request

## PROGRAM SCHEDULE

### COMBISTOP ELECTROMAGNETICALLY ACTUATED DUAL-SURFACE SPRING APPLIED DC BRAKES

Mini brake	0.3 ... 2 Nm	Page 5	<b>COMBISTOP M</b>
Holding brake for dynamic demands	2 ... 1,000 Nm	Page 6	<b>COMBISTOP N</b>
Holding brake for static application	5 ... 1,500 Nm	Page 6	<b>COMBISTOP H</b>
Holding brake for protection class IP 65	5 ... 250 Nm	Page 8	<b>COMBISTOP T</b>
Double-brake for theatre, lift and elevators	2 x 5 ... 2 x 1,000 Nm	Page 10	<b>COMBISTOP D</b>
Accessories		Page 12	

## TECHNICAL DATA

Switching times	Page 15
Dimensions / Calculation	Page 48
Legend	Page 49

## ACCESSORIES

COMBISTOP	M	N	H	T	D	L
Flange	x	x	x	x	x	x
Friction disc		x	x			
Dust protection ring		x	x		x	
Micro switch		x	x		x	x
Hand release	x	x	x	x		x
Terminal box		x	x	x	x	x

stands for MINI Brake, the small compact solution with torques up to 2 Nm. The brake is characterized by a particular compact construction, it is designed for small loads and holding functions without torque adjustment and adjustability and available with or without hand release.

**Range of application:**

e.g. general machine building, small-power motors, automation technique, apparatus engineering.

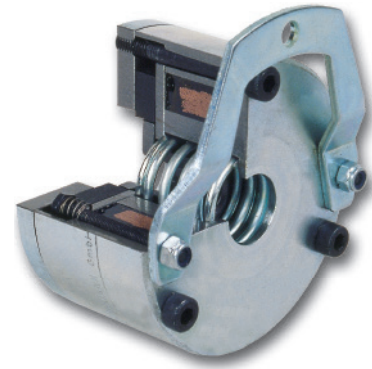

SIZE	T <sub>2N</sub> <sup>1)</sup> [Nm]	P <sub>20</sub> [W]	A	B	C <sub>1</sub>	D <sup>2)</sup> max.	F	G	H	K	N	O	P	T	U	V	W	X	a <sub>1</sub>	b <sub>1</sub>	c	e	g	h	m <sup>3)</sup>	α°	weight [kg]
0B 08	0.3	6	34	12.5	8	8.3	23	5.5	9.8	11	3.2	30	40	0.1									4.7				0.15
00 08	0.5-2	11-15	59.5	52	10	14	29.5	0.5-1	4.5	16	18	4.3	5	43.5	26	59.5	0.15	41	36.5	2	7	5.5	10.2	0.8	7	0.4	

All dimensions in mm keyway according to DIN 6885/1 according to VDE 0580, isolation class „B“ <sup>1)</sup> rated torque after running in process  
<sup>2)</sup> bore Ø 10 mm H7, otherwise H8 <sup>3)</sup> Mounting dimension „m“ with attracted armature

**COMBISTOP M**

**0B 08 110 ... without hand release**

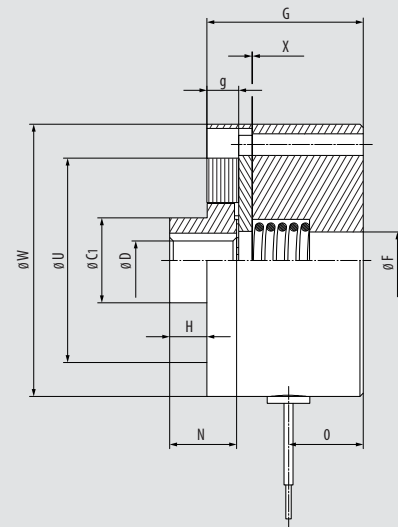
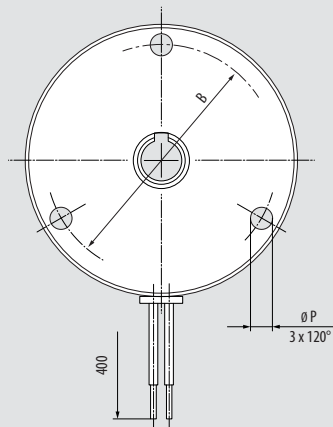

**COMBISTOP M**

**00 08 110 ... without hand release**

**00 08 130 ... with hand release**

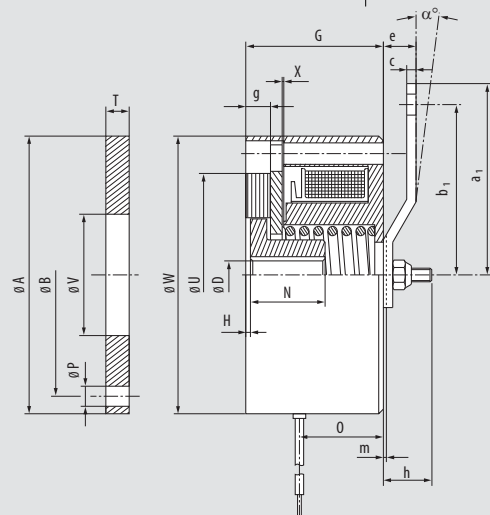
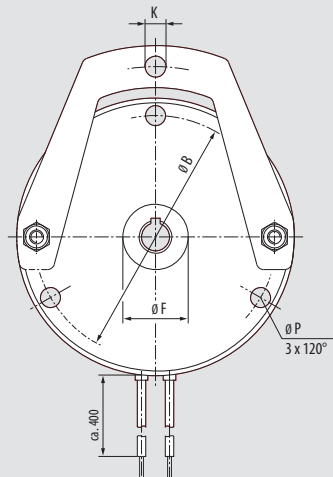

Accessories **COMBISTOP M**

- flange

# COMBISTOP N AND H

COMBISTOP **N** and **H** are the standard series of dual-surface spring-applied brakes in two designs:

- dynamic applications with continuous stress
- static applications with short-term stress

**COMBISTOP N**  
**COMBISTOP H**

## COMBISTOP N:

Rated torque in the range 5 ... 1000 Nm

- designed for dynamic applications with regular brake applications at high speed!

## Range of application:

e.g. brake motors, geared brake motors, wind energy plants, refrigerated warehouses

## Option:

- Cold Climate Version CCV (-40 ... +60 °C)
- ISO-class F + H

## Accessories **COMBISTOP N**

- Flange
- Friction disc (up to size 06)
- Duats protection ring
- Micro switch

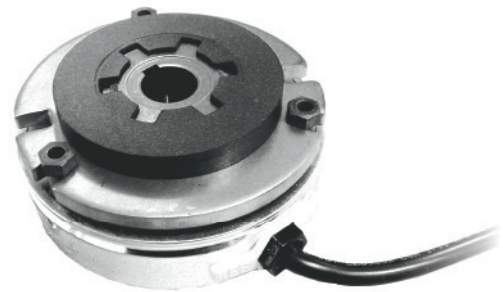

**COMBISTOP N** - dynamic operation

**COMBISTOP H** - static operation

.. 3811**X**.. without hand release

.. 3813**X**.. with hand release

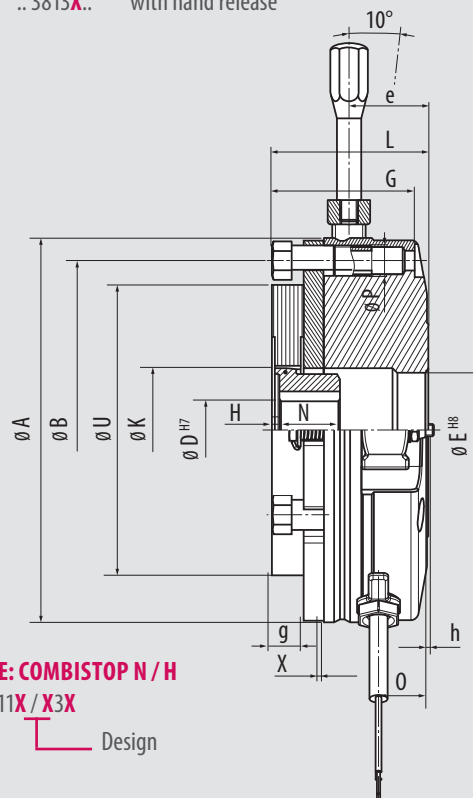
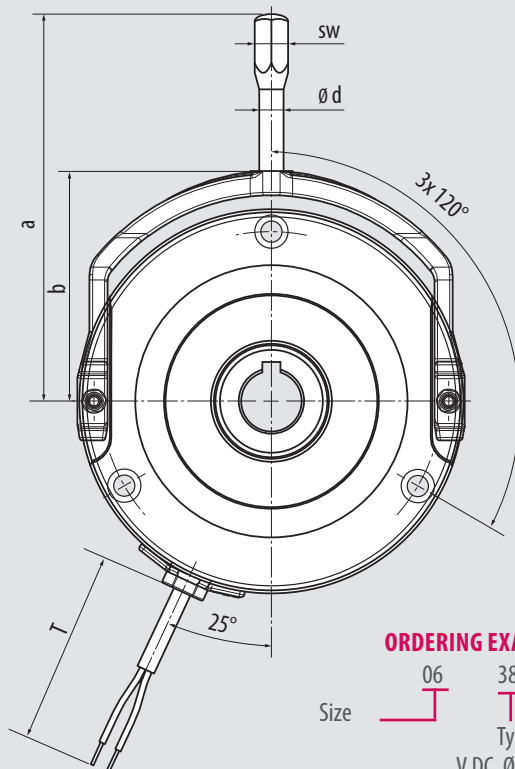

## ORDERING EXAMPLE: COMBISTOP N / H

Size 06 38 11X/X3X Design  
Type  
V DC, ø D ?

SIZE	Version „N“ <sup>1)</sup>		Version „H“ <sup>1)</sup>		A	B	D max.	E	G	H	K	L	N	O	P	T	U	X	a	b	d	e	g	h	sw	weight [kg]
	T <sub>2N</sub> <sup>1)</sup> [Nm]	P <sub>20</sub> [W]	T <sub>2N</sub> <sup>1)</sup> [Nm]	P <sub>20</sub> [W]																						
<b>02</b>	5	25	7.5	25	85	72	15**	22	34.2	1-1.5	22	37.7	18	11.5	3x4.2	500	60	0.2	105.5	53.5	8	23	7.5	-	11	1
<b>03</b>	10	30	15	30	102	90	20	32	37.2	2-2.5	31	41.7	20	13	3x5.3	500	77	0.2	114	62	8	25.5	8	-	11	1.5
<b>04</b>	20	30	30	30	127	112	25	38	47.2	2-2.5	37	51.7	20	16.5	3x6.5	500	96	0.2	128	76	8	26.2	10.5	1.8	11	3
<b>05</b>	36	48	50	48	147	132	30	42	52.7	2.5-3	42	57.7	25	18.5	3x6.5	500	115	0.2	166	86	10	30.5	12	1.8	14	4.5
<b>06</b>	70	62	90	75	164	145	35**	47	59.8	2.5-3	42	68.8	30	20	3x8.5	500	115	0.3	176	96	10	39.5	12	-	14	7
<b>07</b>	100	65	150	90	190	170	45	62	68	3	57	75.5	30	21.5	3x8.5	750	149	0.3	225	115	14	41	14	-	17	10
<b>08</b>	150	75	225	90	218	196	60	78	80	4.5	57/76*	87.4	35	27	3x8.5	750	175	0.4	235	125	14	46.5	16	-	17	16
<b>09</b>	250	80	375	115	253	230	60	97	88.2	5	76	101.7	40	28	3x10.5	750	206	0.4	256	146	14	56	18	-	17	26
<b>10</b>	500	130	750	180	307	278	75	120	98.8	9.5	92	110.8	50	25	6x10.5	750	252	0.5	335	175	16	59	22	-	19	39
<b>11</b>	1000	180	1500	280	363	325	90	140	122.1	-	-	134.5	100	30.5	6x12.5	1000	300	0.6	***	***	***	***	30	***	***	80

All dimensions in mm keyway according to DIN 6885/1 Standard voltage 24 / 105 / 180 / 205 V DC according to VDE 0580, isolation class „B“, 100% on time, Type of protection IP40, with dust protection ring IP44

<sup>1)</sup> rated torque after running in process \* hub bore > ø 45 \*\* keyway according to DIN 6885/3 \*\*\* mech. release with hexagon screw

**COMBISTOP H:** Rated torque in the range 7.5 ... 1,500 Nm - designed for static applications, i.e. braking from low speeds and secure holding of loads!

### Range of application

e.g. electronically controlled or regulated drives, wind energy plants, refrigerated warehouses

### Accessories **COMBISTOP H**

- Flange
- Friction disc (up to size 06)
- Dust protection ring
- Micro switch



# COMBISTOP T

A brake design which are always used whenever the application puts higher demands on the protection class.

## COMBISTOP T:

the IP 65-brake with identical hole circle such as COMBISTOP N and H, optionally completely closed on the backside or prepared for the attachment of tacho-generators or shaft sealing ring.

### Range of application:

e.g. general machine building, crane construction, ship gear, wind energy plants, refrigerated warehouses

## COMBISTOP T

- ..28G10** standard version without hand release
- ..28G20** standard version with hand release
- ..28G1T** for tacho-generators without hand release
- ..28G2T** for tacho-generators with hand release
- ..28G1W** for shaft sealing ring without hand release
- ..28G2W** for shaft sealing ring with hand release

SIZE	T <sub>2N</sub> <sup>1)</sup> [Nm]	P <sub>20</sub> [W]	A	A <sub>1</sub>	B	C	D [max.]	E	E <sub>1</sub>	F	G	H	K	L	L <sub>1</sub>	M	M <sub>1</sub>	N	O
02	5	25	98	102	72	34	15**	53.5	86	94.5	88	1-1.5	22	39	38	2.4	88 x 3	18	25.5
03	10	30	118	123	90	37	20	64	107	116	109.5	2-2.5	31	42.8	41.8	2.4	110 x 3	20	24.8
04	20	30	143	148	112	47	25	80	130	139	132	2-2.5	37	52.8	51.8	2.4	132 x 3	20	35
05	36	48	165	170	132	51.5	30	102	148	158.5	152	2.5-3	42	58.3	57.3	2.4	152 x 3	25	40.5
06	70	62	180	186	145	60	35**	115	168	176.5	170	2.5-3	42	68.8	67.8	2.4	170 x 3	30	48
07	100	65	210	216	170	68	45	144	197	206	196	3	57	74.2	73.2	3.5	196 x 4	30	54
08	150	75	240	246	196	77	60	160	217	235.5	225	4.5	57 76*	86.5	85.5	3.2	225 x 4	35	61.5
09	250	80	276	280	230	88	60	180	254	272	260	5	76	102	101	3.5	260 x 5	40	69

SIZE	P	P <sub>1</sub>	P <sub>2</sub>	R	T	T <sub>4</sub>	V	X	a	b	d	e	f	g	k	l	s	sw	β	Weight [kg]
02	4.2	8	M4	0.5	500	6	37	0.2	105.5	53.5	8	15.5	22	34	7	41	M4	11	10	1.3
03	5.3	11	M5	1.5	500	7	48	0.2	114	62	8	18.5	32	40	7	52	M5	11	10	2
04	6.5	11	M6	1.5	500	9	60	0.2	128	76	8	25.5	38	54	7	66	M5	11	10	3.5
05	6.5	11	M6	2	500	9	70	0.2	166	86	10	30.5	42	64	7	76	M5	14	10	5
06	8.5	15	M8	2	500	11	70	0.3	176	96	10	64	47	75	7	88	M5	14	15	8.5
07	8.5	15	M8	2	750	12	75	0.3	225	115	14	34	62	85	8	100	M6	17	15	14
08	8.5	15	M8	3.5	750	14	95	0.4	235	125	14	76.3	78	100	8	120	M6	17	15	18
09	10.5	18	M10	4.0	750	15	95	0.5	256	145	14	69	78	110	8	130	M6	17	15	28

see dimensions diagram 28.M01-3-0031

All dimensions in mm keyway according to DIN 6885/1 standard voltage 24/105/180/205 V DC according to VDE 0580, ISO-class „B“, 100% on time,  
<sup>1)</sup> rated torque after running in process \* hub bore > ø 45 \*\*keyway according to DIN 6885/3, Attention: under the fixing screws are sealing washer (DIN7603) have to be used



**Option**

- Cold Climate Version CCV (-40 ... +60 °C)
- ISO class F + H

**Accessories COMBISTOP T**

- Flange
- Hand release
- Shaft sealing ring

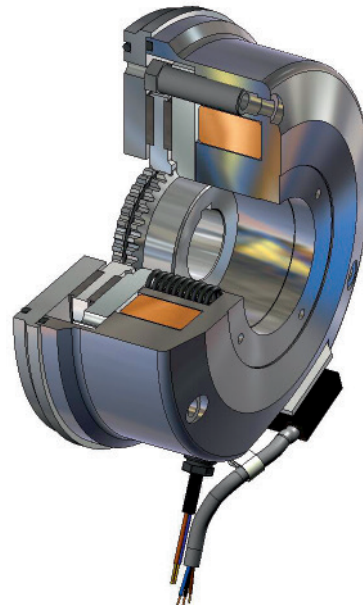

**ORDERING EXAMPLE: COMBISTOP T**

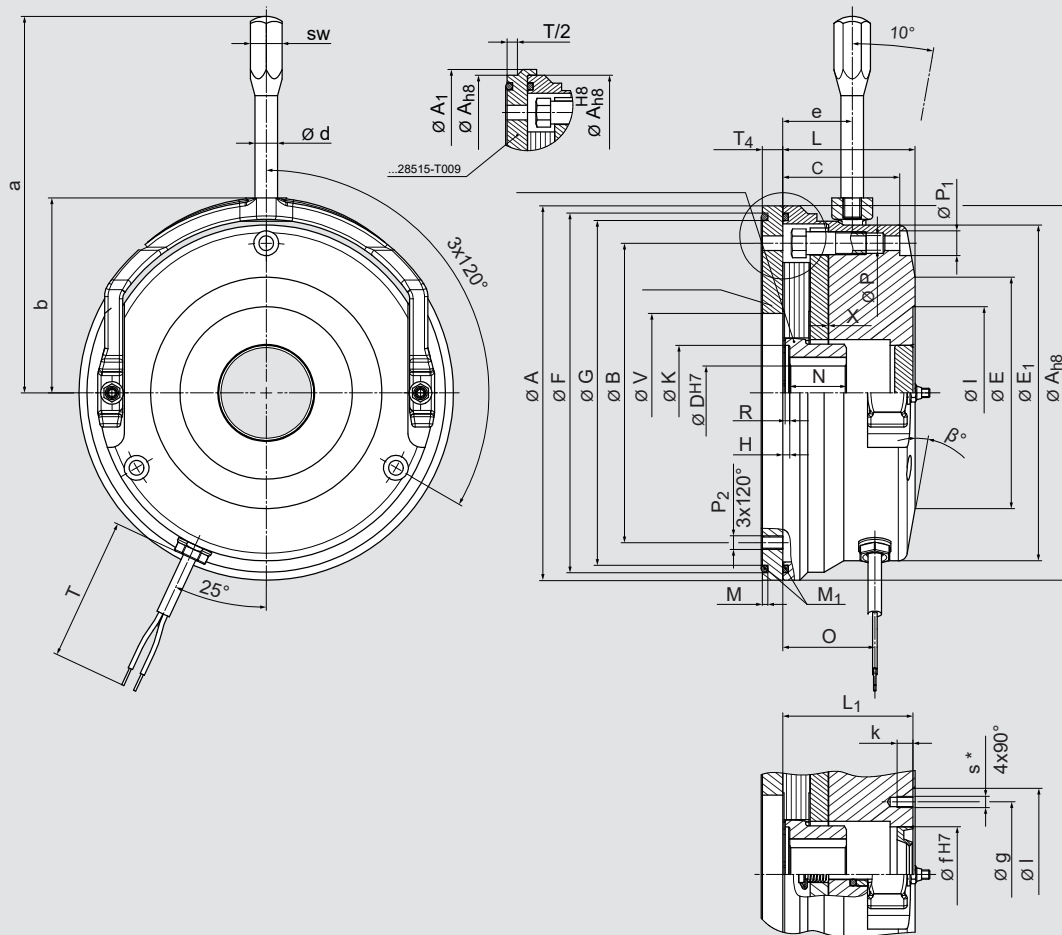
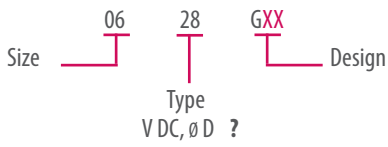

# COMBISTOP D AND L

**COMBISTOP D** stands for double safety and covers a series of double brakes, which is prepared for tasks with redundant brake circuits.

The mechanical construction with two completely independent fail-safe spring-applied brakes meets the requirements according to DIN 56950 (BGV C1).

The brakes are supplied ex factory, ready for attachment with preadjusted air gaps.

Extensive constructional measures reduce the switching and running noises to a minimum.

**Range of application:** e. g. theatre equipment, passenger and freight elevators

**Option:** ISO class F

see dimension diagram 38.003-3-0714

SIZE	T <sub>2N</sub> <sup>1)</sup> [Nm stat.]	P <sub>20</sub> [W]	A	B	C	D <sub>1</sub> /D <sub>2</sub> [max.]	E	F	H	L <sub>1</sub>	L <sub>2</sub>	M	N <sub>1</sub>	N <sub>2</sub>	R <sub>1</sub>	T
02	2x5	2x25	85	72	22	15**	36	36	92	9.5	1.5	18	27.5	13	8	500
03	2x10	2x30	102	90	32	20	48	48	106	12.5	2.5	20	34	17	10	500
04	2x20	2x30	127	112	38	25	60	60	121	12.5	2.5	20	39	23	10	500
05	2x36	2x48	147	132	42	30	70	70	135	14	3	25	41	21	11	500
06	2x70	2x62	164	145	47	35**	70	70	157	16	3	30	45	20	13	500
07	2x100	2x65	190	170	62	45	75	75	180	18.5	3	30	59	37	15	750
08	2x150	2x75	218	196	78	60	100	100	192	19.5	5	35	55	33	14.5	750
09	2x250	2x80	254	230	97	60	100	100	223	22	5.5	40	65	45	16.5	750
10	2x500	2x130	306	278	120	75	120	120	241	27	10	50	63	36	17	750
11	2x1,000	2x180					on request									

SIZE	X	a	b	d <sub>1</sub>	d <sub>2</sub>	e <sub>1</sub>	e <sub>2</sub>	m	Z 1/2/3	FASTENING SCREWS			Weight [kg]
									Z <sub>1</sub>	Z <sub>2</sub>	Z <sub>3</sub>		
02	0.2	105.5	53.5	34.2	39.4	45.5	22.5	0.8	M4	3x8.8	3x8.8	3x8.8	2.5
03	0.2	114	62	37.2	47.5	54	27	1	M5	3x8.8	3x8.8	3x8.8	4
04	0.2	128	76	47.2	51.4	65	31	1.4	M6	3x8.8	3x8.8	3x8.8	7
05	0.2	166	86	52.7	55.9	72	33	1.5	M6	3x10.9	3x8.8	3x8.8	11
06	0.3	176	96	59.8	64.6	81	36	1.8	M8	3x10.9	3x8.8	3x8.8	16
07	0.3	225	115	68	77.1	94	45	2	M8	6x8.8	3x8.8	3x8.8	26
08	0.3	235	125	79.9	82.1	97	50	2	M8	6x10.9	3x10.9	3x10.9	35
09	0.3	256	146	88.9	94.9	107	56	2.3	M10	6x8.8	3x10.9	3x10.9	55
10	0.4	335	175	98.6	105	121	61	2.7	M10	6x10.9	6x8.8	3x8.8	85
11													

All dimensions in mm keyway according to DIN 6885/1 standard voltage 24 / 105 / 180 / 205 V DC according to VDE 0580, ISO-class „B“, 100% on time,  
1) rated torque after running in process \* hub bore > ø 45 \*\* keyway according to DIN 6885/3

Accessories **COMBISTOP D**

- Micro switch
- Dust protection ring
- Flange
- Friction disc (up to size 06)

**ORDERING EXAMPLE: COMBISTOP D**

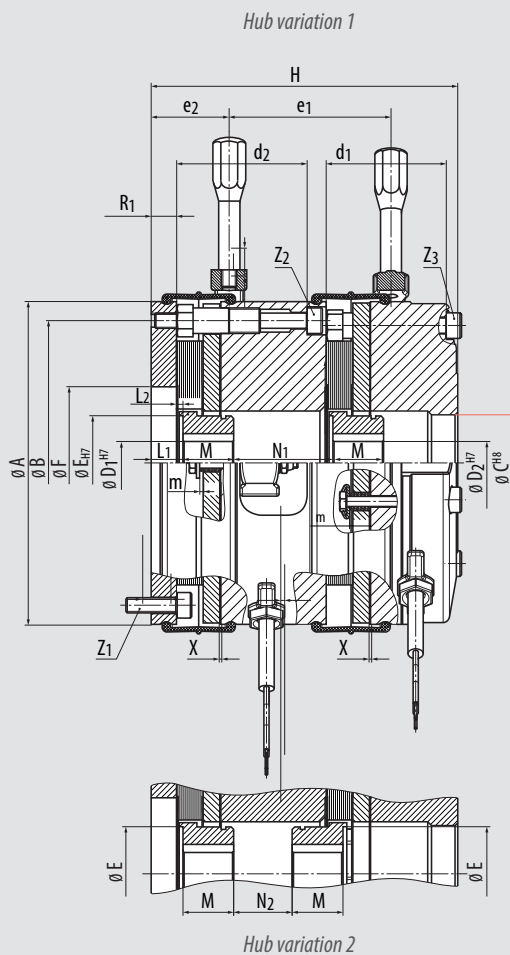
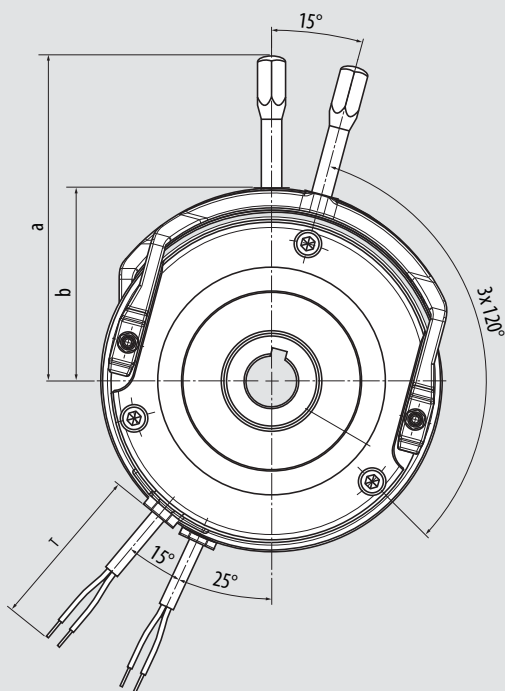
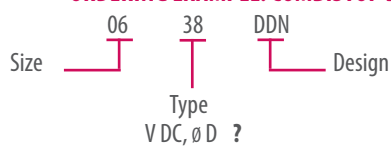

# COMBISTOP ACCESSORIES

To adapt the spring-applied brakes to the various requirements of different applications an extensive program with a wide range of accessories is available.

Please contact us to discuss your requirements. To ensure correct selection we have on hand an experienced team of application engineers to assist you in all aspects of selection, enabling you to get the optimum solution.

## ACCESSORIES - DUST PROTECTION RING (IP44) .. 08 550 0009

	ARTICLE NUMBER XX08550 0009									
SIZE	02	03	04	05	06	07	08	09	10	11
B <sub>1</sub>	22,5	25	33	33,5	38,5	45,5	49	54,5	63	upon request!
W <sub>5</sub>	86	103	129	149	167	195	222	259	310	

All dimensions in mm

To protect the friction surfaces against dust or dripping water different sizes of dust protection rings are available. When fitting the COMBISTOP with a dust protection ring the friction disc **xx38515-xxxx** must be used on the motor side. This friction disc will be supplied nitrated and is especially designed to hold the dust protection ring.

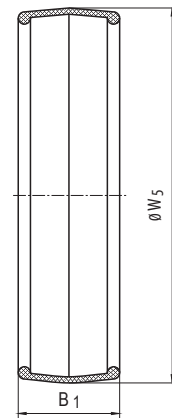

## ACCESSORIES - MICRO SWITCH

The use of COMBISTOP can be fitted with a micro switch for monitoring the functions or the wear.

The use of COMBISTOP with micro switch is particularly sensible for braking motors on hoisting gears that are operated with frequency inverters.

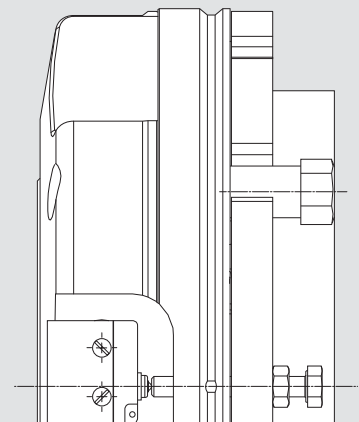

Friction discs and flanges provide suitable counter-rotation surfaces for the spring applied brakes and are available in hardened and rustproof design.

### ACCESSORIES - FRICTION DISC .. 38 515 ....

#### ARTICLE NUMBER XX08515 XXXX

SIZE	02	03	04	05	06	07	08	09	10	11
<b>B</b>	72	90	112	132	145					
<b>P</b>	4.5	5.5	6.5	6.5	9					
<b>T<sub>1</sub></b>	1.5	1.5	1.5	1.5	1.5					
<b>V<sub>1</sub></b>	37	48	60	72	72					
<b>W<sub>1</sub></b>	86	106	131.5	152	170					
<b>Weight [kg]</b>	0.05	0.10	0.15	0.25	0.35					

All dimensions in mm

### ACCESSORIES - FLANGE WITH COLLAR FOR DUST PROTECTION RING .. 38 510 ....

#### ARTICLE NUMBER XX38510 0009

SIZE	00	02	03	04	05	06	07	08	09	10	11
<b>B</b>	52	72	90	112	132	145	170	196	230	278	325
<b>P<sub>4</sub></b>		3x4,3	3x5,3	3x6,4	3x6,4	3x9	3x9	3x9	3x11	6x11	6x13
<b>S<sub>1</sub></b>		3xM4	3xM5	3xM6	3xM6	3xM8	3xM8	3xM8	3xM10	6xM10	6xM12
<b>T<sub>4</sub></b>	5	6	7	9	9	11	11	11	11	12,5	20
<b>V<sub>4</sub></b>	26	20	30	40	45	55	65	75	90	120	160
<b>W<sub>3</sub></b>	60	83	100	125	145	163	190	217	254	306	363
<b>Weight [kg]</b>	0,08	0,20	0,35	0,75	1	1,50	2,10	2,70	3,70	5,90	12,7

All dimensions in mm

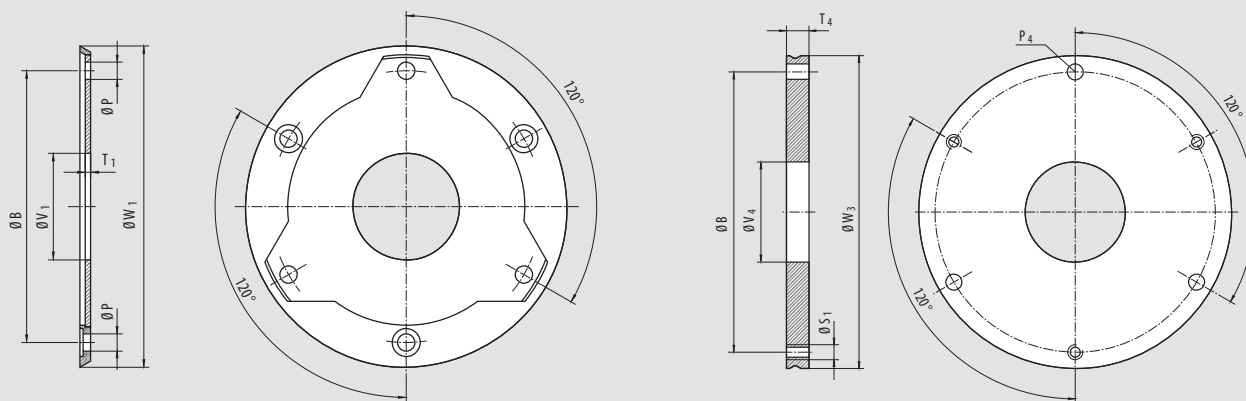

# COMBISTOP TECHNICAL DATA

SIZE	Operating-stop [rpm]	max. speed		J		G <sub>min</sub> [mm]	X <sub>N</sub> [mm]
		Type M. T emergency stop [rpm]	Type N. H. D emergency stop [rpm]	Type M. T [10 <sup>-3</sup> kgm <sup>2</sup> ]	Type N. H. D <sup>1)</sup> [10 <sup>-3</sup> kgm <sup>2</sup> ]		
00	3,000	6,000	-	0.001	-	-	-
02	3,000	6,000	6,000	0.025	0.025	5.5	0.4
03	3,000	6,000	6,000	0.072	0.072	6.5	0.5
04	3,000	6,000	6,000	0.136	0.136	8	0.6
05	3,000	5,000	5,000	0.35	0.35	10	0.6
06	3,000	5,000	5,000	0.56	0.56	10	1
07	3,000	4500	4500	1.57	1.57	10	1
08	3,000	3500	3500	5.92	5.92	11	1.2
09	1,500	3,000	3,000	7.38	7.38	12	1.2
10	1,500	3,000	3,000	20.54	20.54	14	1.5
11	1,500	3,000	2,000		180.7	28	1.5

*gmin* min. permissible lining thickness [mm] 1) for brake type D use for calculation 2 x [J]

## PERMISSIBLE FRICTION $W_{Rmax}$ [J] DEPENDENT THE SWITCHING FREQUENCY

Valid only for the stated revolutions per minute

type **M, T, N, H, D** size 00 ... 07 - 3000 rpm

type **T, N, H, D** size 08 ... 11 - 1500 rpm

The values for  $W_{Rmax}$  are valid for standard brakes and a second friction surface of casting. Depending on application these values may be exceeded or remained under. Rustfree friction discs, or speeds higher than specified in the diagram, reduce the permissible friction work considerably. If the rated torque of the brake is reduced by turning the adjustment ring (optional) the permissible friction work increases.

Friction switching frequency Type M, T

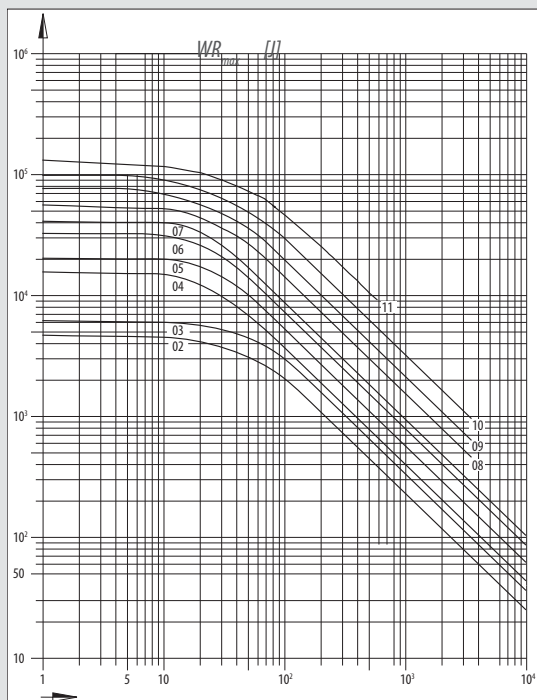

switching frequency per hour  
Red line for brake without friction disc

Friction switching frequency Type N, H, D

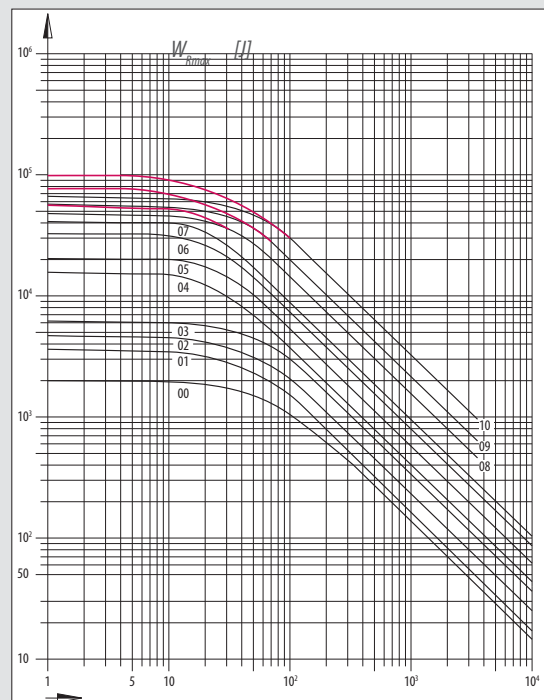

switching frequency per hour

## SWITCHING CYCLES AND SWITCHING TIMES

SIZE	SWITCHING CYCLES						AC-SWITCHING				DC-SWITCHING			
	SC <sub>1</sub>		SC <sub>2</sub>		t <sub>2</sub>		t <sub>11~</sub>		t <sub>1~</sub>		t <sub>11=</sub>		t <sub>1=</sub>	
	M, T	N, H, D	M, T	N, H, D	M, T	N, H, D	M, T	N, H, D	M, T	N, H, D	M, T	N, H, D	M, T	N, H, D
00	70		140		35		60		100		12		25	
02	60	60	120	120	40	40	40	70	90	100	10	10	20	20
03	40	60	75	75	60	55	80	100	140	150	15	15	30	30
04	40	60	75	75	100	90	140	180	200	200	20	25	50	50
05	25	25	50	50	120	110	180	220	240	240	25	25	55	55
06	5	5	10	10	240	240	200	260	330	330	25	25	90	90
07	5	5	10	10	240	220	400	400	650	650	50	40	150	120
08	5	5	10	10	300	320	700	700	900	900	60	50	180	180
09	2	2	5	5	350	350	900	900	1,200	1,200	60	60	220	220
10	1	2	3	3	350	400	1,400	1,400	1,800	2,000	60	100	250	300
11		1		2		750		3,100		3,500		450		1000

SC<sub>1</sub> applicable for rectifiers:

0291010-CE07

0291020-CE07

0291010-CEMV

SC<sub>2</sub> applicable for rectifiers:

0491010-CE07

0491020-CE07

0591010-CE09

0691010-CE09

COMBISTOP Typs: M, T, N, H, D (see page 4)

### SC maximum permissible switching cycle

at DC-side switching, 100% on time and max. operating temperature of 80 °C.

[rpm]

### t<sub>1</sub> engaging time

time from disconnecting the current to attaining 0,9 T<sub>2N</sub>.

[ms]

### t<sub>11</sub> engaging delay time

time from disconnecting the current to the rise of the torque.

[ms]

### t<sub>2</sub> release time

time from connecting the current to the beginning of torque decrease.

[ms]

The designation of the switching times corresponds to DIN VDE 580

## SWITCHING CYCLES COMBISTOP WITH POWERBOX

SIZE	t <sub>2</sub>	max. air gap	switching cycles
	[ms]	[mm]	[rpm]
02	20	1.0	55
03	35	1.8	40
04	50	2.1	40
05	60	3.0	25
06	120	3.0	5
07	120	3.5	5
08	150	3.0	5
09	170	3.5	2
10*	180	4.5	1

### POWERSUPPLY

COMBISTOP requires DC voltage for operation. For the power supply different half-wave or full-wave rectifiers of the series COMBITRON 98 are available for DC or AC-side switching, which, depending on the type, are suitable for connection voltages up to 720 V AC rated voltage.

The switching characteristics and functions of the COMBISTOP can be optimized through the rapid switch rectifier COMBITRON 98..

\* Continuous operation only permissible 45 °C!

230 V AC input voltage and 105 V DC coil Switching times apply to rated air gap X  
Switching cycles apply to DC side switching

# COMBIPERM PROGRAM SCHEDULE

COMBIPERM are electromagnetically released permanent magnet brakes and clutches for dry operation whose flux is generated by permanent magnets. This effect permits the connection of shafts in voltage free condition or the safe deceleration of masses.

You find possible shaft diameters in the "Bore Table" on page 49.  
On request we adapt COMBIPERM to your constructional and electrical requirements.

## PROGRAM SCHEDULE

### COMBIPERM quiescent-current operated brakes and clutches

Holding brake with Emergency-Stop-function	0.4 ... 145 Nm	page 17	COMBIPERM P1
Clutch quiescent-current operated	6 ... 120 Nm	page 19	COMBIPERM PC

## TECHNICAL DATA

Switching times	page 20
Moments of inertia, friction, -rating	page 21
Dimensioning / Calculation	page 48
Bore table COMBINORM / COMBIPERM	page 49

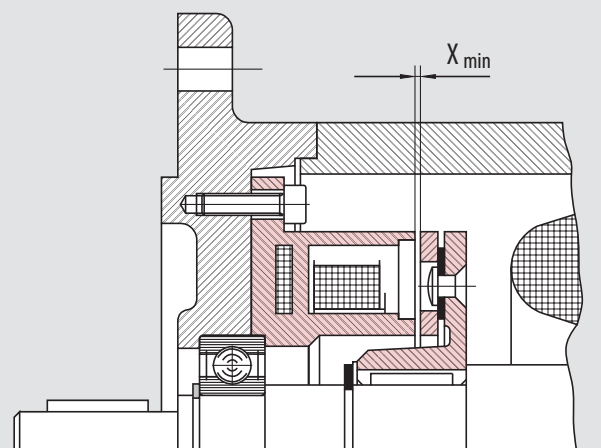

COMBIPERM P1

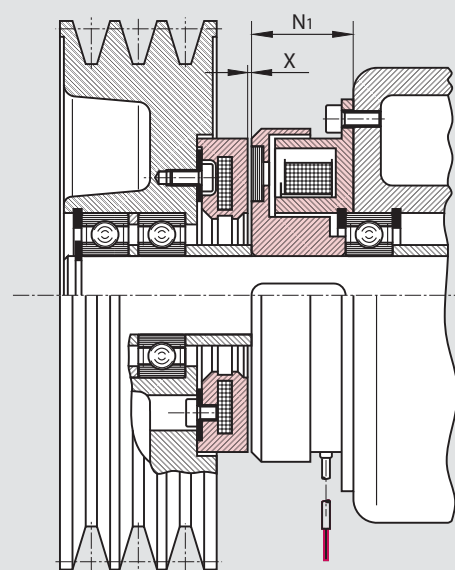

COMBIPERM PC



**COMBIPERM P1 FIRST CHOICE FOR YOUR SERVOMOTOR**

are powerful permanent magnet brakes with frictionally engaged, backlash-free effect. Rare earth magnets create a force field, which is cancelled by the counter-pole magnet coil (opened) in current-supplied condition and in combination with the membrane spring on the armature it ensures a residual torque-free separation independent of the installation position.

COMBIPERM P1 are designed for rated operating voltage 24 V DC according to ISO class F (max. 155 °C) and ensure a safe operation within a wide range of temperatures. On request versions in other operating voltages are available.

certified to  on request



**Range of application:** e.g. machine building, medical technology, industrial robots, servo-drives

Please bear in mind

- that magnetic materials within the direct surroundings can weaken the torque, reduce maximal air gaps and lead to a shifting of the release range.
- that the rated torques are achieved after a required running-in process (please see instruction manual).
- that the torques become less at higher speeds

**ORDERING EXAMPLE: COMBIPERM P1**

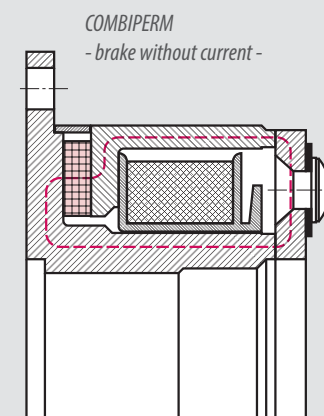
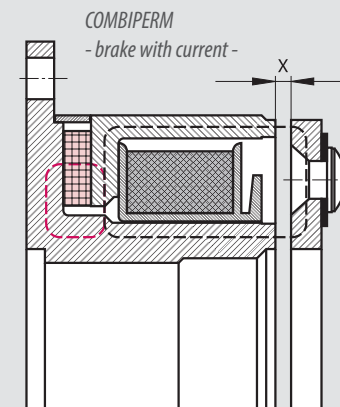
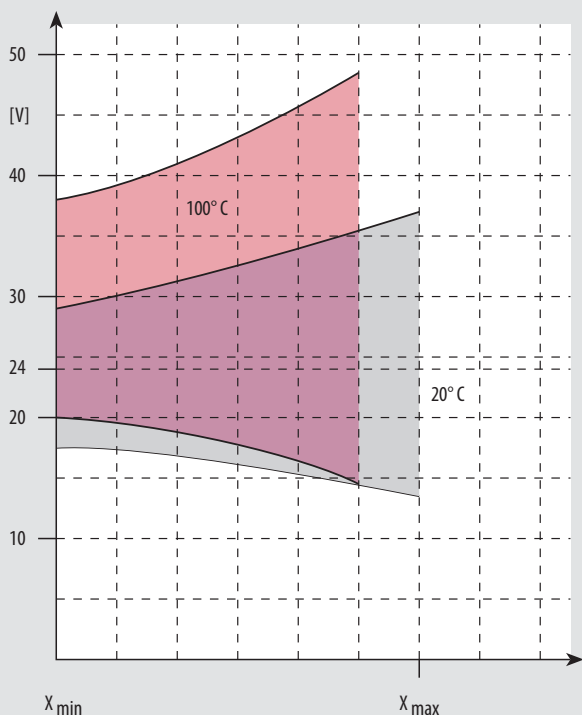
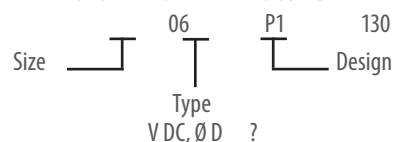

# COMBIPERM P1

SIZE	T <sub>2N</sub> <sup>1)</sup> [Nm]	P <sub>20</sub> [W]	A <sub>h8</sub>	A <sub>1</sub>	A <sub>2h8</sub>	A <sub>3</sub>	B	B <sub>1</sub>	C <sup>H8</sup>	C <sub>1</sub>	C <sub>2</sub>	D	E	ØF	G	H	J	K
01	0.4	8	39	28	28	32	33.5	22	11	13.5	-	28	19.5	3.4	2x2.1	5.3	4.5	-
02	1	10	45	32.2	32	34	38	23	12.5	16	-	32	23	3.4	3x2.6	6	5	-
03	2	11	54	41	40	42	47	28.5	19	22	-	40	30	3.4	3x3.1	6	5.5	-
05	4.5	12	65	51.5	50	53	58	40	26	24	24	50	38	3.4	3x3.1	6.5	5.5	2
06	9	18	80	64	63	66	72	49	35	32	32	63	50	4.5	3x4.1	10	8	2
07	18	24	100	80.8	80	83	90	63	42	38	38	80	60	5.5	3x4.1	11	8	2
08	36	26	125	101	100	103	112	78	52	48	48.5	100	76	6.5	3x5.1	11.5	10	2.5
09	72	40	150	126	125	128	137	106	62	57	58	125	95	6.5	3x6.1	15	11.5	3.5
10	145	50	190	161	160	163	175	135	80	71	75	160	120	9	3x8.1	21	14.5	3.5

SIZE	K <sub>1</sub>	L	L <sub>1</sub>	L <sub>2</sub>	M	N	P	R	R <sub>1</sub>	R <sub>2</sub>	S	d <sub>20</sub> <sup>H7</sup>	d <sub>30</sub> <sup>H7</sup>	d <sub>30</sub> <sup>H7</sup>	X <sub>min</sub>	X <sub>max</sub> <sup>20°</sup>	Z	weight [kg]
01	3	19.5	2	10.5	2xM3	3	1	2.25	4.25	2.7	7	6	6	8	0.15	0.3	1xM3	0.1
02	2	21.5	2	10.5	3xM3	3	1.3	2.1	4.1	4	10	8	8	10	0.15	0.3	1xM3	0.1
03	2	22.5	2	12	3xM3	3	1.5	2.6	5.2	5	12	10	12	15	0.15	0.4	1xM4	0.2
05	2	28.5	2	14	3xM3	3	1.5	3	6	5	12	15	15	19	0.2	0.5	1xM5	0.35
06	3	26.8	3	15	3xM4	4	2	3.9	7.4	6	15	18	18	25	0.3	0.65	1xM6	0.55
07	3	29.9	3	16.5	3xM4	5	2	4.5	8.5	8	20	25	25	30	0.3	0.8	1xM6	0.85
08	4	33.9	4	19.5	3xM5	6.2	2.5	6.2	11.2	10	25	30	30	38	0.35	0.8	1xM8	1.6
09	5	37.8	5	23	3xM6	7	3	7.3	13.3	12	30	40	40	50	0.4	1.0	2xM10	2.9
10	6	42.6	6	24	3xM8	9.5	4	9.4	16.4	15	38	50	50	65	0.5	1.2	2xM10	5.4

All dimensions in mm keyway to DIN 6885/1-P9 standard voltage 24 VDC (release range + 6% / -10%) according to VDE 0580, isolation class "F" hub DIN 6885/1  
<sup>1)</sup> rated torque after running in process

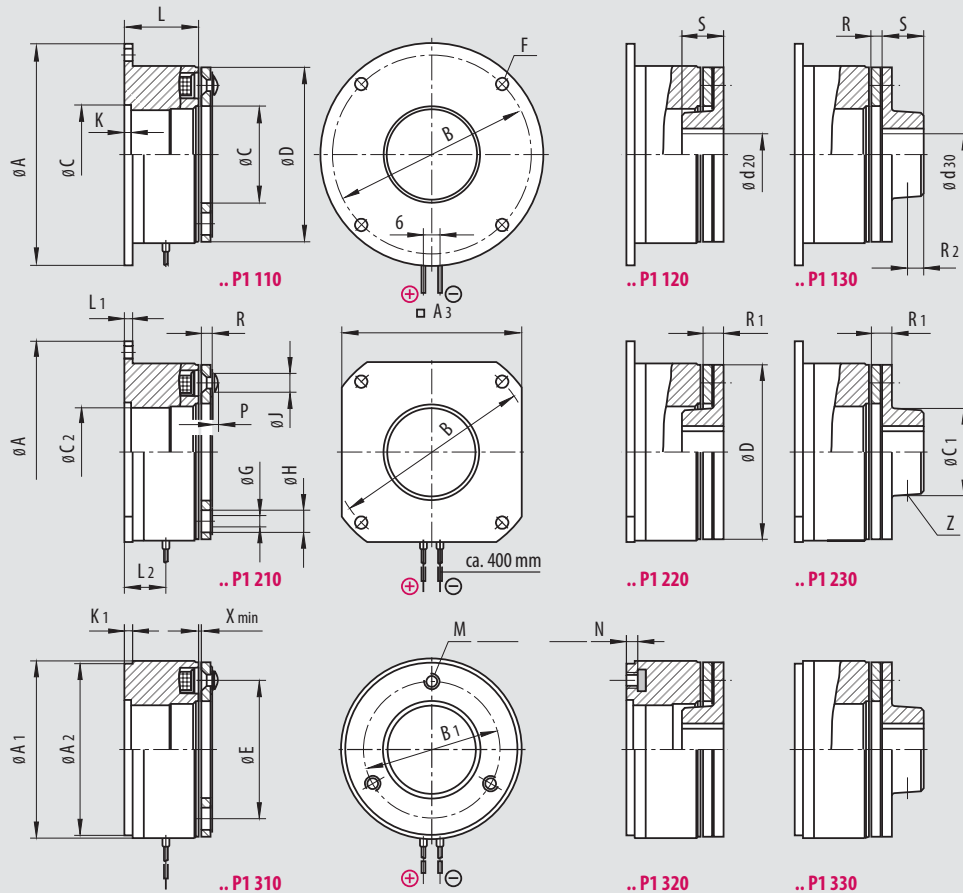

COMBIPERM PC are permanent magnet clutches, which transmit in currentless condition frictionally engaged torque. The magnetic circle is optimized by the arrangement of the permanent magnets in the armature, thus permitting the transmission of high torques on small constructional spaces. The opening of the friction-type connection takes place by the antipole connection of the electromagnetic circuit, thereby neutralizing the force action of the permanent magnets

**Range of application:** e.g. robot technique, medical equipment

SIZE	$T_{2N}^{1)}$ [Nm]	$P_{20}$ [W]	Data
06	6	18	upon request
07	12	24	
08	24	28	
09	50	35	
10	120	50	

1) rated torque after running in process

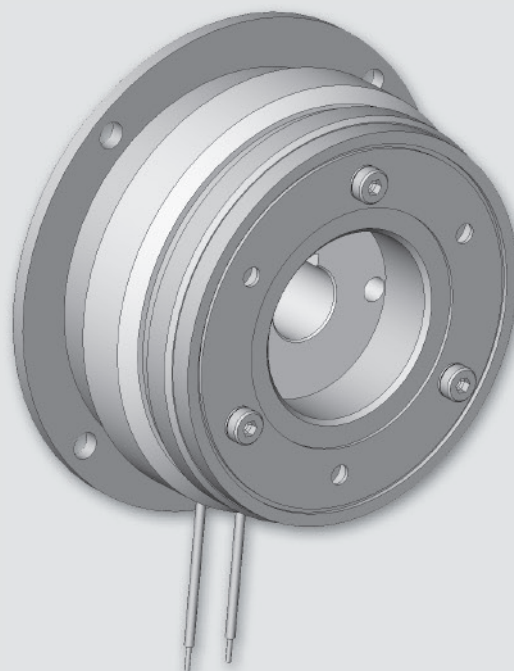

xxPC110-xxxx

# COMBIPERM TECHNICAL DATA

Permissible friction  $W_{Rmax}$  [J] depending on the switching frequency type P1

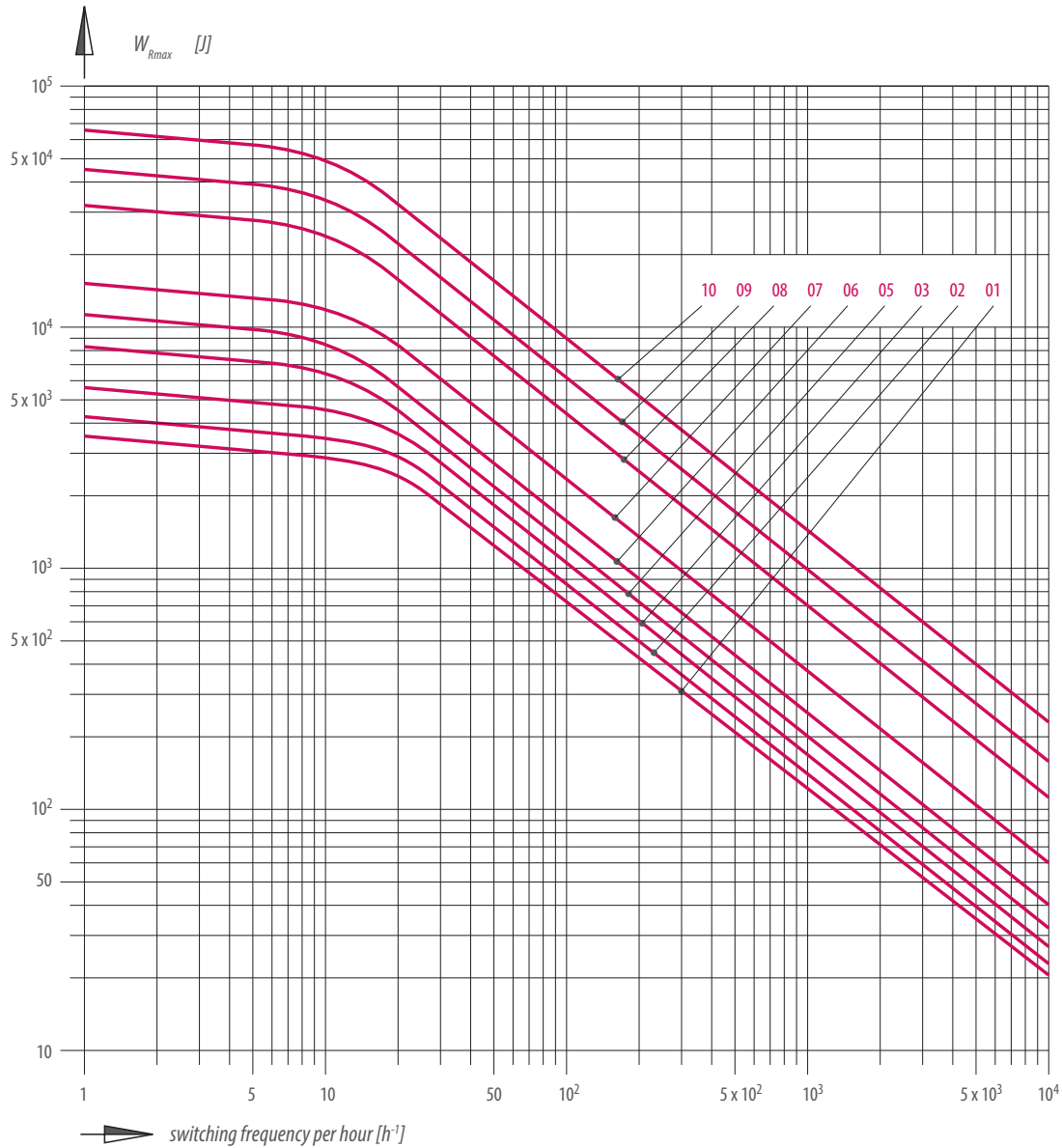

The values for  $W_{Rmax}$  apply to a speed 3000 rpm. Dependent on the actual application  $W_{Rmax}$  may exceed or fall below these values..

## POWER SUPPLY

COMBIPERM P1 needs a smoothed DC voltage. To ensure a safe operation in case of large temperature variations, the coil should be supplied with constant current.

Please pay attention to the polarity of the connection leads.  
(positive = **red**, negative = **black**).

**COMBIPERM P1**

SIZE			01	02	03	05	06	07	08	09	10
$T_{2N}$	20 °C	[Nm]	0.4	1	2	4.5	9	18	36	72	145
$T_{stat.}$	100 °C		0.35	0.8	1.8	4	8	15	32	62	130
$T_{dyn.}$	20 °C	[Nm]	0.3	0.8	1.7	3.8	7.5	15	28	55	110
		[kgm <sup>2</sup> ]	0.001	0.001	0.001	0.001	0.002	0.004	0.012	0.036	0.1
		[rpm]	3,000	3,000	3,000	3,000	2,000	2,000	2,000	2,000	2,000
$P_{20}$		[W]	8	10	11	12	18	24	26	40	50
<b>J</b>											
<b>Armature</b>	P1.110	[10 <sup>-4</sup> kgm <sup>2</sup> ]	0.01	0.014	0.045	0.122	0.37	1.15	4	11.5	39
	P1.120/130		0.013	0.021	0.068	0.18	0.54	1.66	5.56	16	53
$W_{R0,1}$		[kJ]	200	300	410	580	890	1,290	2,900	6,200	13,000
		[kgm <sup>2</sup> ]	0.001	0.001	0.001	0.001	0.0015	0.004	0.0120	0.036	0.1
		[rpm]	3,000	3,000	3,000	3,000	2,000	2,000	2,000	2,000	2,000
$X_{max}$	20 °C	[mm]	0.3	0.3	0.4	0.5	0.65	0.8	0.9	1	1.2
$X_{min}$			0.15	0.15	0.15	0.2	0.3	0.3	0.35	0.4	0.5
$n_{max}$		[rpm]	10,000	10,000	10,000	10,000	10,000	10,000	10,000	8,000	8,000
<b>Switching times</b>	$t_2$	[ms]	10	12	25	35	40	50	90	140	190
	$t_{11} =$		2	2	2	2	2	3	3	7	12
	$t_1 =$		6	6	6	7	7	10	22	25	65

**LEGEND**

$T_{2N}$	rated torque after running in process (slip speed 20 rpm)	[Nm]	$t_1$	<b>Engaging time:</b> Time from disconnecting the current until 0,9 $T_{2N}$ is attained	[ms]
$T_{stat.}$ 100 °C	rated torque at 100 °C (slip speed 20 rpm)	[Nm]	$t_{11}$	<b>Engaging delay time:</b> Time from disconnecting the current until the torque rises	[ms]
$T_{dyn.}$ 20 °C	switching torque at specified conditions	[Nm]	$t_2$	<b>Release time:</b> Time from connecting the current until the torque decreases	[ms]
$P_{20}$	power at 20 °C	[W]			
<b>J</b>	moment of inertia	[kgm <sup>2</sup> ]			
$n_{max}$	max. speed	[rpm]			
$X_{min}$	nominal air gap	[mm]			
$X_{max}$	max. air gap at which the armature attracts	[mm]			
$W_{R0,1}$	friction work up to 0.1 mm abrasion	[kJ]			

The stated switching times are achieved with adjusted nominal air-gap ( $x_{min}$ ). These are averages whose dispersion depends on the power supply and coil temperature.

# COMBINORM PROGRAM SCHEDULE

COMBINORM - operating-current operated brakes and clutches use the flux of an electromagnet, concentrated on two pole surfaces, for the connecting, separating or holding of shafts and the connected loads.

COMBINORM covers a complete program with brakes, clutches and combinations as installation and attachment components for the applications in machines, plants and equipment in the application range of 0.5 to 500 Nm.

On request we adapt the KEB COMBINORM to your constructional and electrical requirements. Please bear in mind that the rated torques are achieved after a required running-in process.

## PROGRAM SCHEDULE

### COMBINORM OPERATING-CURRENT OPERATED BRAKES AND CLUTCHES

Operating current brake	0.5 ... 500 Nm	page 24	<b>COMBINORM B</b>
Operating current clutch	0.5 ... 500 Nm	page 26	<b>COMBINORM C</b>
Operating current toothed clutch	21 ... 390 Nm	page 31	<b>COMBINORM T</b>

### FLANGE MOUNTED BRAKE

**COMBINORM B** .. 02 120 ....

- ① brake magnet
- ② armature
- ⑤ hub
- ⑥ spring

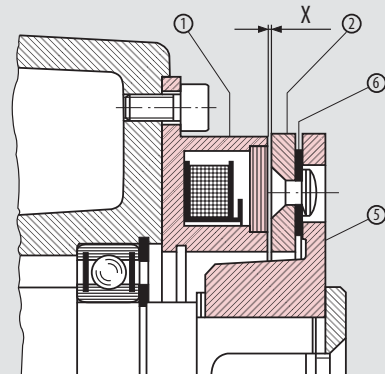

### FLANGE MOUNTED CLUTCH

**COMBINORM C and T** .. 03 110 ....

- ② armature
- ③ clutch magnet
- ④ rotor
- ⑥ spring

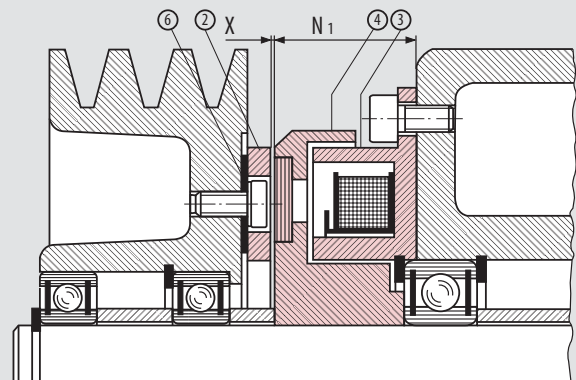

**TECHNICAL DATA**

Switching times	page 32
Moments of inertia, friction, rating	page 33
Dimensioning / Calculations	page 48
Bore table COMBINORM / COMBIPERM	page 49

**ORDERING EXAMPLE: COMBINORM C**

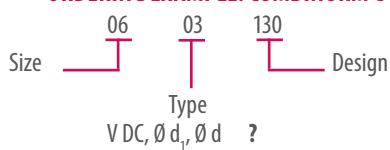

**SHAFT MOUNTED CLUTCHES**

**COMBINORM C and T .. 03 810 ....**

- ② armature
- ③ clutch magnet
- ④ rotor
- ⑥ spring

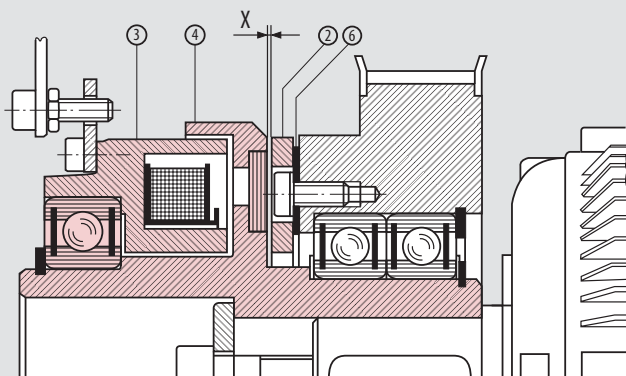

# COMBINORM B

SIZE	$T_{2N}^{(1)}$ [Nm]	$P_{20}$ [W]	$A_{h8}$	B	$C^{H8}$	$C_1$	$C_2$	$d/d_4$ max.	$d_5$	D	E	F	G	H	J	K	$K_1$	M
01	0.5	6	39	33.5	11	13.5	-	6		28	19.5	3.4	2 x 2.1	5.3	4.5	-	-	9.3
02	0.75	6	45	38	13	16	13.6	8		32	23	3.4	3 x 2.6	6	5	3	1.1	12.1
03	1.5	8	54	47	19	22	20	10		40	30	3.4	3 x 3.1	6	5.5	3	1.1	14.7
05	3	10	65	58	26	24	27	15		50	38	3.4	3 x 3.1	6.5	5.5	3.2	1.3	15
06	7	12	80	72	35	32	36	20	18	63	50	4.5	3 x 4.1	10	8	3.5	1.6	18.8
07	15	16	100	90	42	38	43.5	22	21	80	60	5.5	3 x 4.1	11	8	4.25	1.85	24.3
08	30	21	125	112	52	48	53.8	30	28	100	76	6.6	3 x 5.1	11.5	10	5	2.15	31
09	65	28	150	137	62	58	63.8	35	35	125	95	6.6	3 x 6.1	15	11.5	5.5	2.15	36.9
10	130	38	190	175	80	73	82.1	45	44	160	120	9	3 x 8.1	21	14.5	6	2.65	46.9
11	250	50	230	215	100	92	102.1	60		200	158	9	3 x 10.1	19	17.5	7	3.15	59.2
12	500	65	290	270	125	112	127.4	70		250	210	11	4 x 12.1	28	20.5	8	4.15	68
13	Dimensions and technical data see drawing 02.004-4-01001																	

available shaft diameters page 49

All dimensions in mm  $\emptyset$  „d“ keyway according to DIN 6885/1-P9 (design ..02110/120/130)  $\emptyset$  „d4“ keyway according to DIN 6885/1-H8 (design ..02230)

COMBINORM B are the most economical solution for the deceleration and holding of loads for the flange- and shaft-mounted installation in machines and plants.

The magnets with a rated voltage of 24 V DC are designed according to ISO class B and are available in various special voltages on request.

## SHAFT MOUNTED BRAKES

COMBINORM B .. 02 320 ....

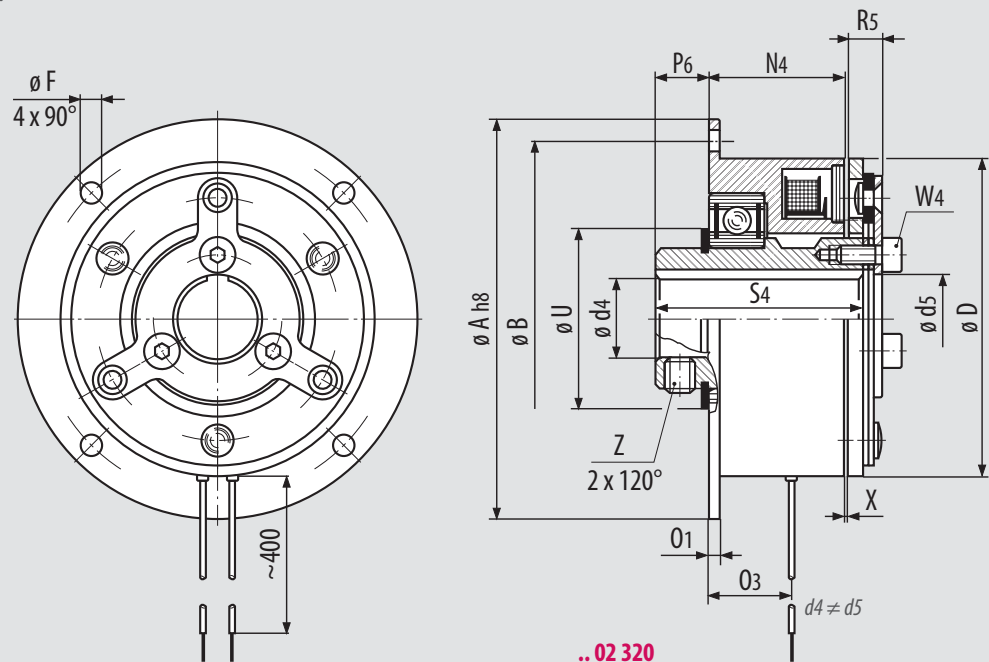



N	N <sub>4</sub>	O	O <sub>1</sub>	O <sub>3</sub>	P	P <sub>6</sub>	R	R <sub>1</sub>	R <sub>5</sub>	S	S <sub>4</sub>	U	V <sub>1</sub>	W <sub>4</sub>	X	Z	Z <sub>1</sub>	weight [kg]		
																		110	120/130	320
13.7		5	1.5		1		2.3	4.3		7			2.5		0.1		1 x M3	0.05	0.05	
17		7.5	2		1.3		2.1	4.1		10			4		0.15		1 x M3	0.1	0.1	
20		7	2		1.5		2.7	5.3		12			5		0.15		1 x M4	0.15	0.15	
22		7.5	2		1.5		3	6		12			5		0.2		1 x M5	0.2	0.25	
18	31.2	6	3	19	2	9.3	3.8	7.3	6.3	15	45	39	6	M4	0.2	M6	1 x M6	0.3	0.3	0.8
20	34.2	7	3	21.5	2	13.2	4.3	8.3	6.9	20	52.5	45	8	M5	0.2	M8	1 x M6	0.5	0.6	1.5
22	38	8	4	24	2.5	13.5	6	11	9.3	25	58.5	56	10	M6	0.2	M8	1 x M8	0.9	1.1	2.7
24	40	9	4	25	3	13.8	6.9	12.9	10.9	30	62	61	12	M8	0.3	M8	2 x M10	1.7	2	4.2
26	46.3	11	5	31.5	4	17.3	8.9	15.9	14.1	38	74	84	15	M10	0.3	M10	2 x M10	3.2	4	7.8
30		12	5		4.5		11.2	20.2		48			19		0.4		2 x M12	5.9	7	
35		15	6		5		13	24		55			22		0.4		2 x M12	11.2	13.5	

Standard voltage 24 V DC VDE 0580, ISO-class „B“ <sup>1)</sup> rated torque after running in process

**Range of application:** e.g. mail processing, winding equipment, door and gate systems, roller conveyor, strapping machines, balancing machines, sorting machines.

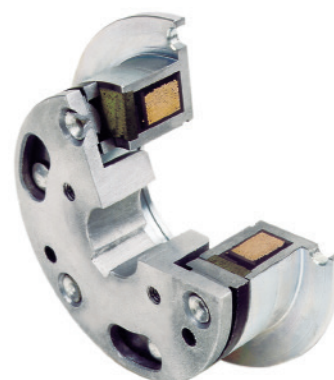

**FLANGE MOUNTED BRAKE**  
COMBINORM B .. 02 1X0 ....

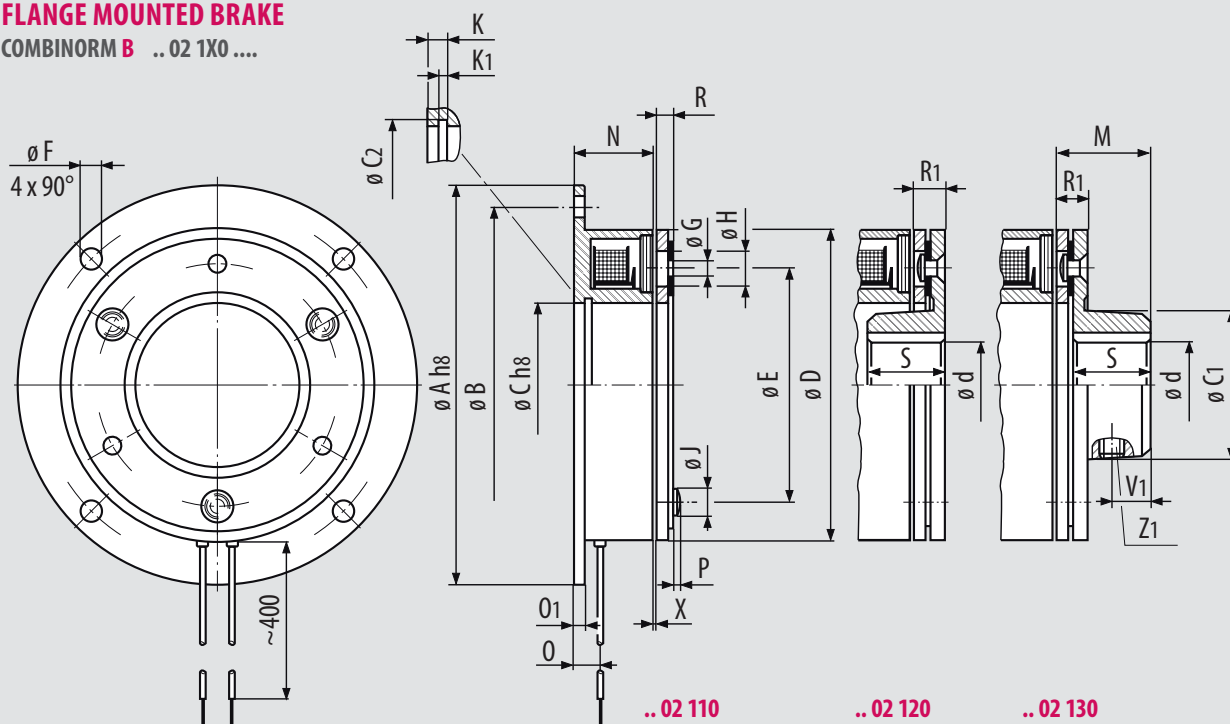

# COMBINORM C

## FLANGE MOUNTED CLUTCHES

SIZE	$T_{2N}^{1)}$ [Nm]	$P_{20}$ [W]	$A_{h8}$	B	$C^{H8}$	$C_1$	$C_2$	d max.	$d_1$ max.	D	E	F	G	H
01	0.5	6	39	33.5	11	13.5	-	6	6	28	19.5	3.4	2 x 2.1	5.3
02	0.75	6	45	38	13	16	13.6	8	8	32	23	3.4	3 x 2.6	6
03	1.5	8	54	47	19	22	20	10	10	40	30	3.4	3 x 3.1	6
05	3	10	65	58	26	24	27	15	15	50	38	3.4	3 x 3.1	6.5
06	7	15	80	72	35	32	36	18	20	63	50	4.5	3 x 4.1	10
07	15	20	100	90	42	38	43.5	22	25	80	60	5.5	3 x 4.1	11
08	30	28	125	112	52	48	53.8	30	30	100	76	6.6	3 x 5.1	11.5
09	65	35	150	137	62	58	63.8	35	35	125	95	6.6	3 x 6.1	15
10	130	50	190	175	80	73	82.1	45	50	160	120	9	3 x 8.1	21
11	250	68	230	215	100	92	102.1	60	65	200	158	9	3 x 10.1	19
12	500	85	290	270	125	112	127.4	70	80	250	210	11	4 x 12.1	28

SIZE	J	K	$K_1$	M	$N_1$	O	$O_1$	P	R	$R_1$	S	$S_1$	T	$V_1$	X	$Z_1$	Weight [kg]	
																	110	130
01	4.5	-	-	9.3	18	5	1.5	1	2.3	4.3	7	16.5	31	2.5	0.1	1 x M 3	0.1	0.1
02	5	3	1.1	12.1	22.2	7.5	2	1.3	2.1	4.1	10	20.2	34	4	0.15	1 x M 3	0.1	0.1
03	5.5	3	1.1	14.7	25.4	7	2	1.5	2.7	5.3	12	23.4	43	5	0.15	1 x M 4	0.2	0.2
05	5.5	3.2	1.3	15	28.1	7.5	2	1.5	3	6	12	26.1	54	5	0.2	1 x M 5	0.35	0.4
06	8	3.5	1.6	18.8	24	6	3	2	3.8	7.3	15	22	67	6	0.2	1 x M 6	0.5	0.5
07	8	4.25	1.85	24.3	26.5	7	3	2	4.3	8.3	20	24	85	8	0.2	1 x M 6	0.9	1
08	10	5	2.15	31	30	8	4	2.5	6	11	25	27	106	10	0.2	1 x M 8	1.6	1.8
09	11.5	5.5	2.15	36.9	33.5	9	4	3	6.9	12.9	30	30	133	12	0.3	2 x M 10	2.8	3.1
10	14.5	6	2.65	46.9	37.5	11	5	4	8.9	15.9	38	34	169	15	0.3	2 x M 10	5.6	6.3
11	17.5	7	3.15	59.2	44	12	5	4.5	11.2	20.2	48	40	212.5	19	0.4	2 x M 12	9.7	11
12	20.5	8	4.15	68	51	15	6	5	13	24	55	47	266	22	0.4	2 x M 12	17.9	20.3

available shaft diameters page 49

All dimensions in mm keyway according to DIN 6885/1-P9 Standard voltage 24 V DC VDE 0580, ISO-class „B“ <sup>1)</sup> rated torque after running in process

## FLANGE MOUNTED CLUTCHES

COMBINORM C ..03 1X0 ....

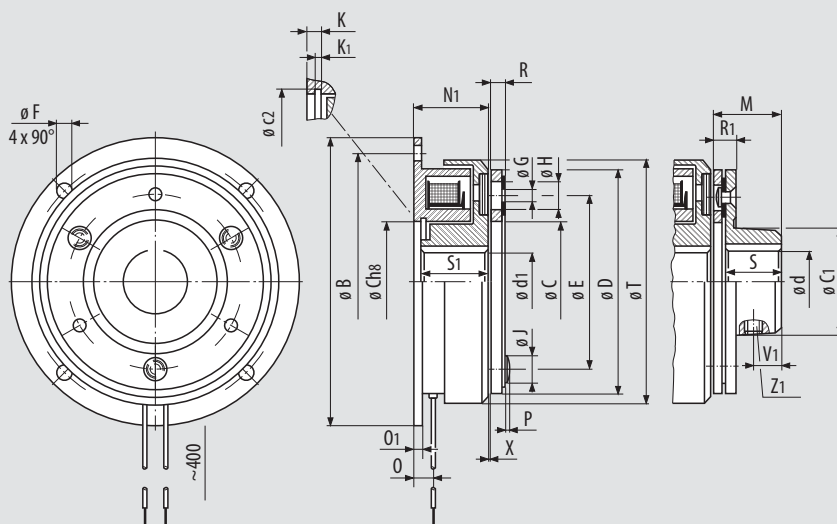

..03 110

..03 130

## SHAFT MOUNTED CLUTCHES SIZE 01 ... 07

SIZE	T <sub>2N</sub> <sup>1)</sup> [Nm]	P <sub>20</sub> [W]	B <sub>1</sub>	C	C <sub>1</sub>	C <sub>4</sub>	d max.	d <sub>2</sub> max.	d <sub>6</sub> max.	D	E	F <sub>1</sub>	G	H	J	L <sub>4</sub>	M	M <sub>1</sub>	N <sub>2</sub>
01	0.5	6	16.8	11	13.5	13	6	6	6	28	19.5	3.1	2 x 2.1	5.3	4.5	4.8	9.3	9.3	17.3
02	0.75	6	20	13	16	14	8	6	6	32	23	3.1	3 x 2.6	6	5	7.8	12.1	12.1	19.8
03	1.5	8	23	19	22	18	10	10	10	40	30	3.1	3 x 3.1	6	5.5	9.1	14.7	14.7	23
05	3	10	28	26	24	28	15	17	15	50	38	3.1	3 x 3.1	6.5	5.5	8.8	15	15	26.1
06	7	15	36	35	32	-	18	20	-	63	50	5.2	3 x 4.1	10	8	-	18.8	-	24
07	15	20	45	42	38	-	22	25	-	80	60	5.2	3 x 4.1	11	8	-	24.3	-	26.5

SIZE	O <sub>5</sub>	P	P <sub>2</sub>	P <sub>4</sub>	Q	R	R <sub>1</sub>	S	S <sub>2</sub>	S <sub>5</sub>	T	U	V <sub>1</sub>	X	Z	Z <sub>1</sub>	Weight [kg]	
																	610	630
01	3.6	1	1.5	8	3	2.3	4.3	7	23.5	9.4	31	17	2.5	0.1	M3	M3	0.1	0.1
02	5	1.3	1.5	8	3	2.1	4.1	10	26.2	12.25	34	21	4	0.15	M3	M3	0.1	0.1
03	5.1	1.5	1.5	8	3	2.7	5.3	12	30.4	14.85	43	23	5	0.15	M4	M4	0.2	0.2
05	7.8	1.5	1.5	8	3	3	6	12	34.1	15.2	54	32	5	0.2	M4	M5	0.35	0.4
06	6	2	2.5	12	7	3.8	7.3	15	33	-	67	41	6	0.2	M4	M6	0.5	0.5
07	7	2	2.5	12	7	4.3	8.3	20	38	-	85	50	8	0.2	M6	M6	0.9	1

available shaft diameters page 49

All dimensions in mm keyway according to DIN 6885/1-P9 Standard voltage 24 V DC VDE 0580, ISO-class „B“ <sup>1)</sup> rated torque after running in process

COMBINORM C the switchable shaft connections are proven millions of times in the machine building and allow the controlled connection and disconnection of functional parts in an especially easy manner. Electromagnets according to ISO class B with rated voltage of 24 V DC create a flux, whose effect leads over the pole surfaces of the rotors and armatures. Available on request in various special voltages.

**Range of application:** e.g. paper processing, winding drives, door and gate systems, feed strapping machines, sorting machines



Flange mounted clutch

## SHAFT MOUNTED CLUTCHES SIZE 01 ... 07

COMBINORM C ..03 6X0 ....

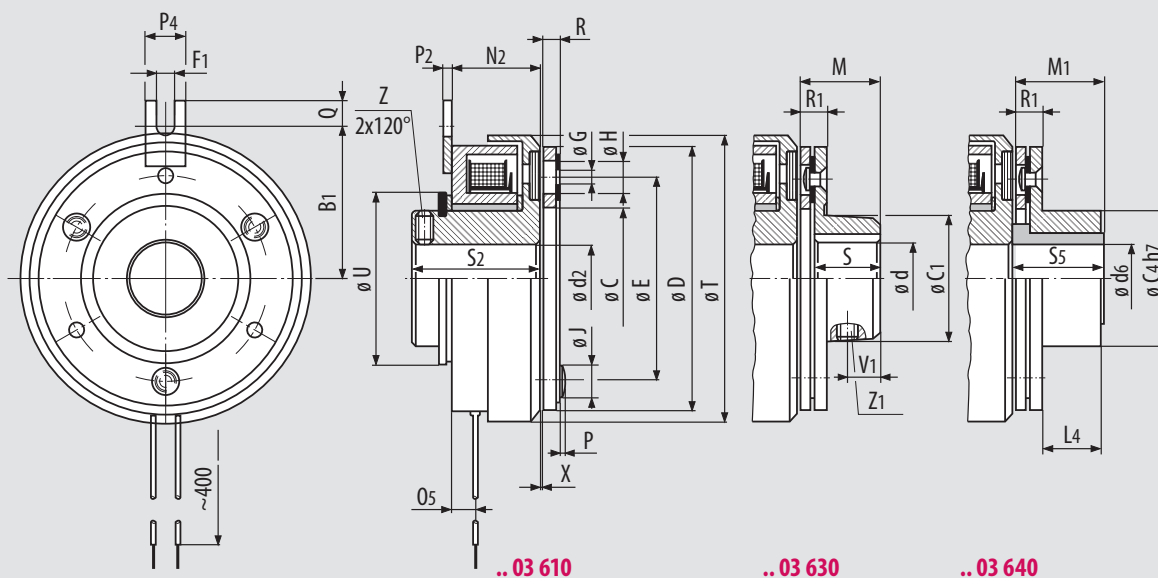

# COMBINORM C

## SHAFT MOUNTED CLUTCHES SIZE 06 ... 12

DIZE	$T_{2N}^{1)}$	$P_{20}$	$A_{h8}$	$A_1$	B	$B_1$	C	$C_1$	d	$d_3$	D	$D_2$	E	$E_1$	F	$F_1$	G	H	J
	[Nm]	[W]							max.	max.									
06	7	15	80	-	72	-	35	32	18	17	63	-	50	-	4.5	-	3 x 4.1	10	8
07	15	20	100	-	90	-	42	38	22	22	80	-	60	-	5.5	-	3 x 4.1	11	8
08	30	28	-	62.5	-	56	52	48	30	30	100	85	76	45.75	-	6.5	3 x 5.1	11.5	10
09	65	35	-	75	-	68.5	62	58	35	35	125	95	95	55	-	6.5	3 x 6.1	15	11.5
10	130	50	-	95	-	87.5	80	73	45	50	160	126	120	72.5	-	9	3 x 8.1	21	14.5
11	250	68	-	115	-	107.5	100	92	60	50	200	126	158	88	-	9	3 x 10.1	19	17.5
12	on request																		

SIZE	M	$O_2$	P	$P_3$	$P_4$	$P_5$	R	$R_1$	S	$S_3$	T	V	$V_1$	W	$W_1$	X	$Z_1$	Weight [kg]	
																		210/710	230/730
06	18.8	19	2	-	-	4	3.8	7.3	15	41	67	-	6	-	-	0.2	1xM6	0.8	0.9
07	24.3	21.5	2	-	-	4.5	4.3	8.3	20	45	85	-	8	-	-	0.2	1xM6	1.5	1.6
08	31	24	2.5	16.2	12	5.5	6	11	25	51.5	106	M5	10	M4	46.5	0.2	1xM8	2.3	2.5
09	36.9	25	3	18.7	14	5.5	6.9	12.9	30	55	133	M8	12	M5	55	0.3	2xM10	3.7	4.1
10	46.9	31.5	4	21.5	14	7	8.9	15.9	38	65	169	M8	15	M5	72.5	0.3	2xM10	7	7.7
11	59.15	32.5	4.5	23	20	7	11.15	20.15	48	71	212.5	M10	19	M6	88	0.4	2xM12	13.1	14.3
12	on request																		

available shaft diameters page 49

All dimensions in mm keyway according to DIN 6885/1-P9 Standard voltage 24 V DC VDE 0580, ISO-class „B“ <sup>1)</sup> rated torque after running in process

## SHAFT MOUNTED CLUTCHES SIZE 06 ... 12

### COMBINORM C .. 03 XX0 ....

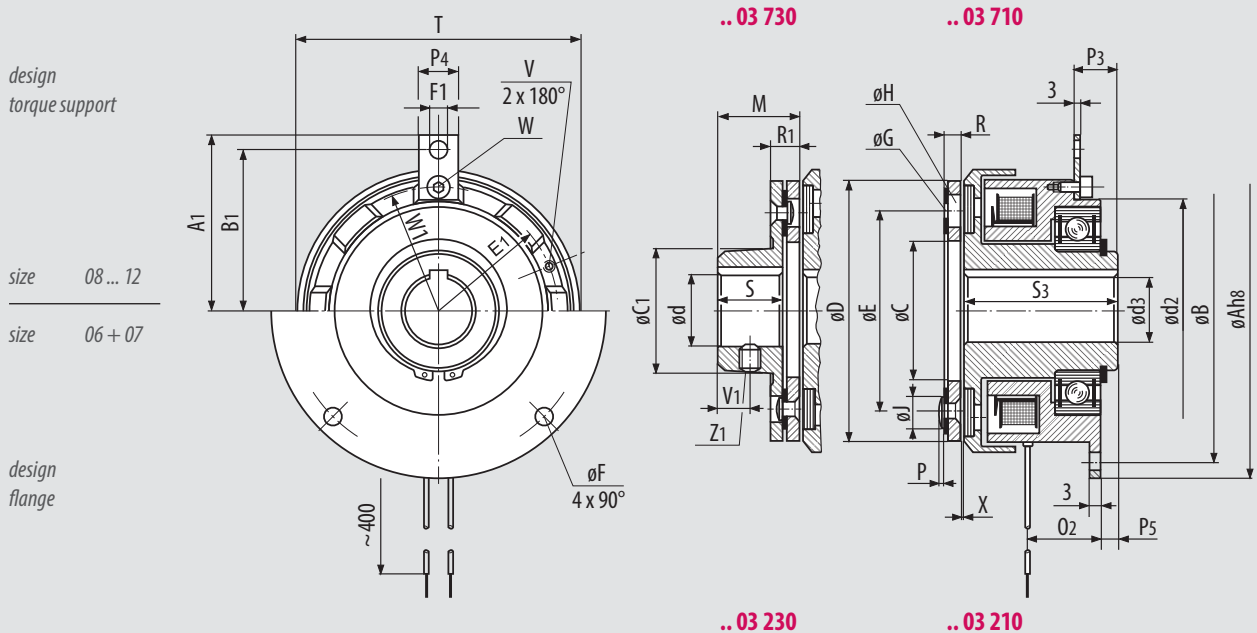

### SHAFT MOUNTED CLUTCHES WITH BEARING TAKE-UP FOR THE OUTPUT

SIZE	$T_{2N}^{1)}$ [Nm]	$P_{20}$ [W]	$M_A^{2)}$ [Nm]	$A_{h8}$	$A_1$	B	$B_1$	$C_5$	D	$D_2$	$D_3$	$D_4$	$d_4$ max.	$d_7$ max.	d	E	$E_1$	$E_2$	F	$J_3$	$K_3$	L
06	7	15	10	80	-	72	-	30	63	-	25	29	19	17	16	50	-	44	4x4.5	2	1.3	32.9
07	15	20	25	100	-	90	-	40	80	-	35	40	26	25	22	60	-	68	4x5.5	4	1.6	37.7
08	30	28	25	-	62.5	-	56	45	100	85	40	46	30	28.5	25	76	45.75	80	-	4	1.85	35.2
09	65	35	50	-	75	-	68.5	60	125	95	50	57	38	33	35	95	55	100	-	4	2.15	37.6
10	130	50	140	-	95	-	87.5	85	160	126	70	76	55	41	50	120	72.5	140	-	6	2.65	47.8
11	250	68	220	-	115	-	107.5	100	200	126	70	76	65	48	50	158	88	165	-	8	2.65	47.5
12	on request																					

SIZE	$L_1$	$L_2$	$L_3$	$M_2$	$M_3$	$M_4$	$O_1$	$O_2$	P	$P_3$	$P_4$	$P_5$	$S_3$	T	$T_1$	V	W	$W_1$	$W_2$	X	Z	Weight [kg]	
																						810	840
06	25.6	80	117	30	24	19	3	19	2	-	-	4	41	67	56	-	-	-	2xM6	0.2	M5	1	1.7
07	29.9	90	129	30	24	20	3	21.5	2	-	-	4.5	45	85	85	-	-	-	2xM8	0.2	M6	1.8	3
08	32.15	96	141	35	28	23	-	24	2.5	16.2	12	5.5	51.5	106	100	M5	M4	46.5	3xM8	0.2	M8	2.7	4.1
09	34.6	103	160	45	32	31	-	25	3	18.7	14	5.5	55	133	120	M8	M5	55	3xM10	0.3	M10	4.2	7.4
10	43.1	126	200	60	46	40	-	31.5	4	21.5	14	7	65	169	170	M8	M5	72.5	3xM14	0.3	M10	8.3	14.6
11	43.3	134	217	65	58	40	-	32.5	4.5	23	20	7	82	212.5	200	M10	M6	88	3xM16	0.4	M12	14.5	24.4
12	on request																						

available shaft diameters page 49

All dimensions in mm keyway according to DIN 6885/1-P9 Standard voltage 24 V DC VDE 0580, ISO-class „B“ 1) rated torque after running in process 2) tightening

### SHAFT MOUNTED CLUTCHES WITH BEARING TAKE-UP FOR THE OUTPUT

COMBINORM C .. 03 810 ....

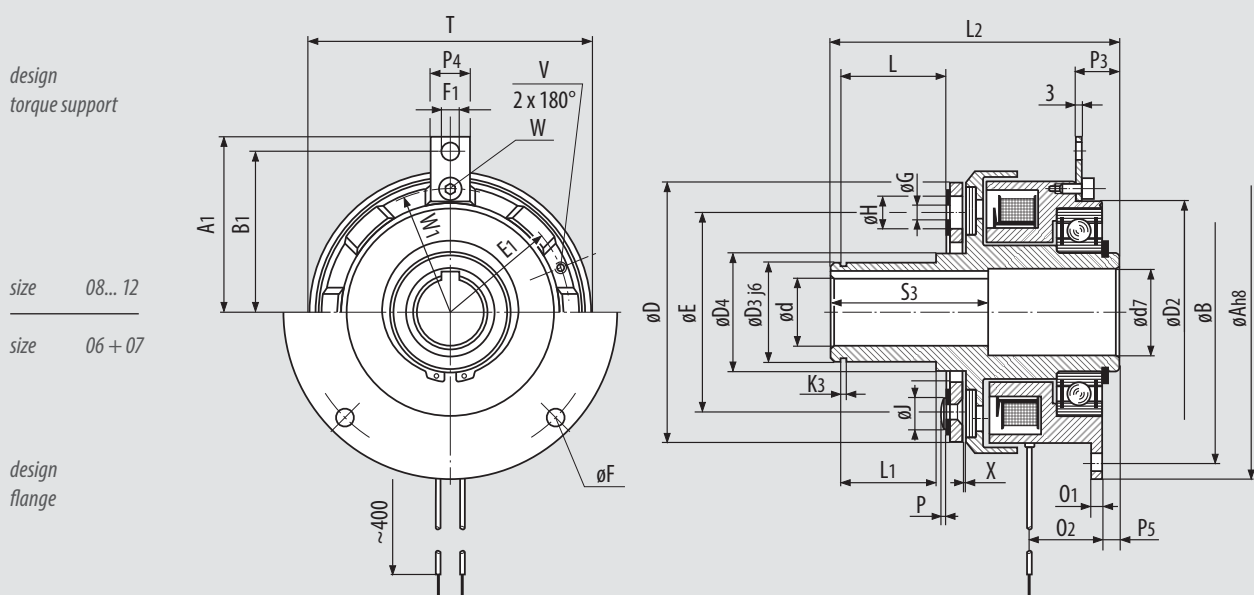

# COMBINORM C

## SHAFT MOUNTED CLUTCHES WITH BEARING TAKE-UP FOR THE OUTPUT

For flexible clutches (type .. 03 840) the following additional instructions are applicable:

The radial and axial screws connecting the rubber element to the hubs must all be tightened to the torque ( $T_A^2$ , table page 29) given in the table, using a torque wrench.

Ensure that when tightening the screws the aluminium bushes do not twist in the rubber part and that they sit squarely.

In order to reduce friction between the screw head and the aluminium bush smear a small amount of grease under the head of the screw before fitting. If necessary use a suitable tool to apply counter pressure on the element to prevent twisting of the rubber part while tightening the screws.

This is particularly important with the radial screws otherwise the curved faces between the aluminium bush and the hub will not engage on the full area but only across the two sides. This will inevitably lead to slackening of the screws and destruction of the clutch. If the clutch is supplied in a pre-assembled state, do not dismantle it, but fit it in this condition.

SIZE	Compliance [mm] of flexible clutches	
	radial	axial
06	1.5	2
07	1.5	3
08	1.5	3
09	2	4
10	2	5
11	2	5
12	2	5

Table page 29

## SHAFT MOUNTED CLUTCHES WITH FLEXIBLE CLUTCH

COMBINORM C .. 03 840 ....

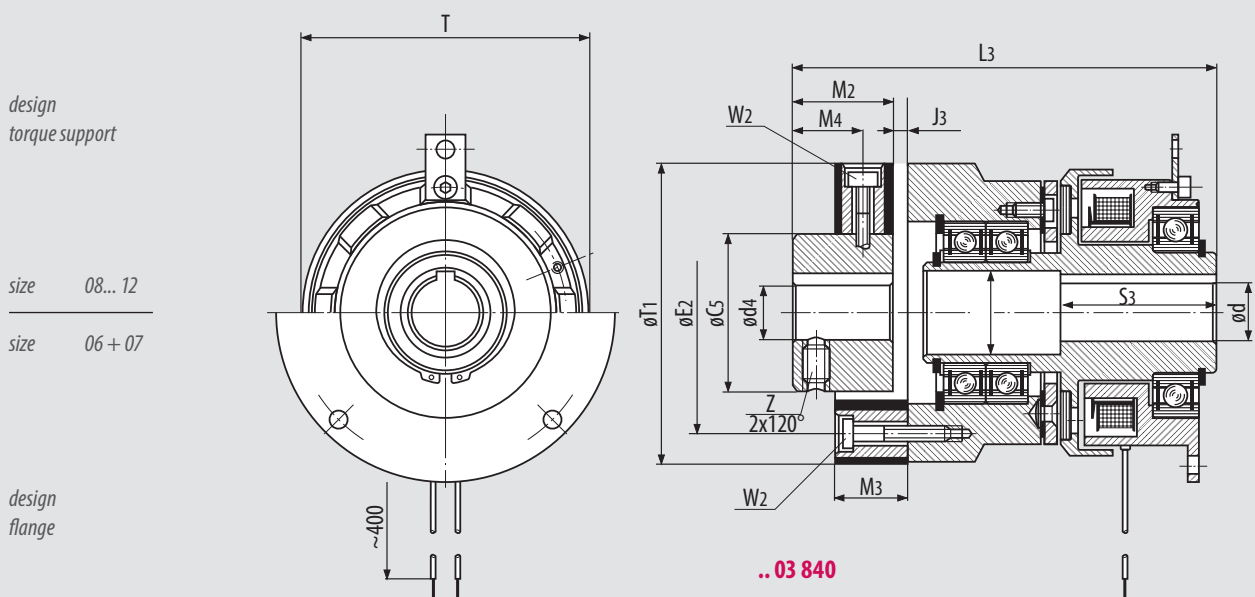

## FLANGE MOUNTED TOOTH CLUTCH

COMBINORM T are electromagnetically operated tooth clutches for wet or dry operation. Torque is transmitted by the leading faces of hardened serrations and is backlash free. Large torques are transmitted with less space requirements in both directions. On request available in various special voltages.

**Range of application** e.g. door drives, printing machines, transport roller, aggregate connection

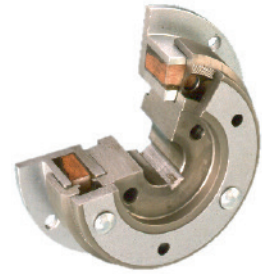

SIZE	T <sub>2N</sub> [Nm]	P <sup>20°C</sup> [W]	A <sub>h8</sub>	B	C <sup>H8</sup>	C <sub>1</sub>	C <sub>2</sub>	D	d <sub>1</sub> max.	d max.	E	F	G	H <sub>1</sub>	J	K
06	21	15	80	72	35	32	36	63	20	18	50	4x4.5	3x4.1	8	8	3.5
07	45	20	100	90	42	38	43.5	80	25	22	60	4x5.5	3x4.1	8	8	4.25
08	90	28	125	112	52	48	53.8	100	30	30	76	4x6.6	3x5.1	11.2	10	5
09	195	35	150	137	62	58	63.8	125	35	35	95	4x6.6	3x6.1	15	11.5	5.5
10	390	50	190	175	80	73	82.1	160	50	45	120	4x9	3x8.1	16	14.5	6

SIZE	K <sub>1</sub>	M <sub>5</sub>	N <sub>1</sub>	O	O <sub>1</sub>	P	R <sub>3</sub>	R <sub>4</sub>	S	S <sub>1</sub>	V	V <sub>1</sub>	X	Z <sub>1</sub>	weight [kg]	
															110	130
06	1.6	20.3	24	6	3	2	5.3	8.8	15	22	-	6	0.15	1xM6	0.7	0.7
07	1.85	26.4	26.5	7	3	2	6.4	10.4	20	24	-	8	0.2	1xM6	1.1	1.2
08	2.15	33.6	30	8	4	2.5	8.6	13.6	25	27	M5	10	0.2	1xM8	1.9	2.1
09	2.15	41.2	33.5	9	4	3	11.2	17.2	30	30	M8	12	0.2	2xM10	3.2	3.5
10	2.65	50.8	37.5	11	5	4	12.8	19.8	38	34	M8	15	0.25	2xM10	6.1	6.9

available shaft diameters page 49

All dimensions in mm keyway according to DIN 6885/1-P9 Standard voltage 24 V DC VDE 0580, ISO-class „B“

## FLANGE MOUNTED TOOTH CLUTCH

COMBINORM T .. 07 1X0 ....

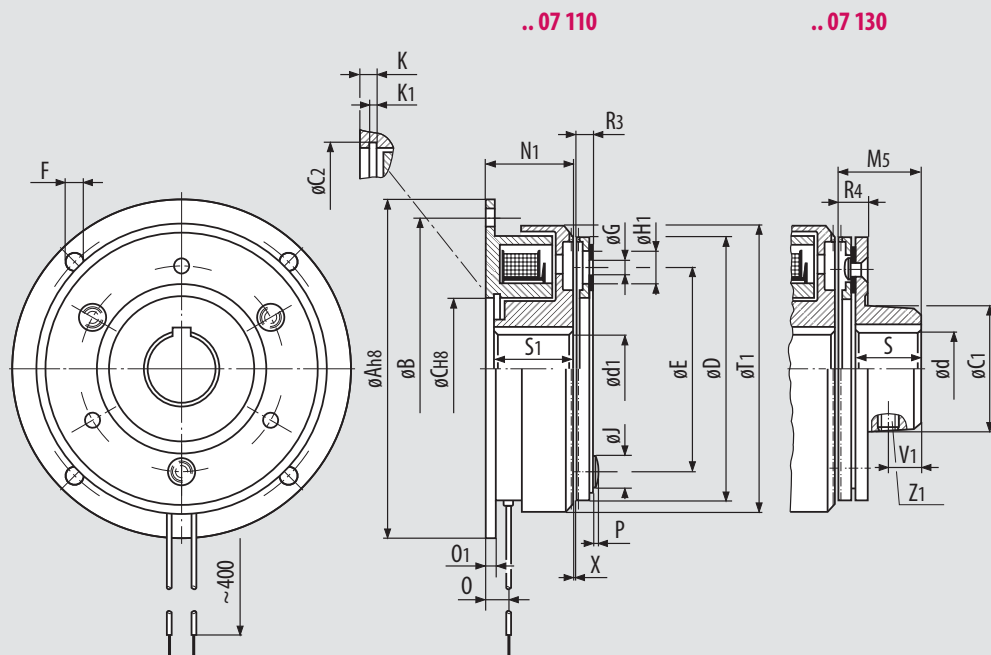

# COMBINORM TECHNICAL DATA

## COMBINORM 02 / 03 / 07

SIZE				01	02	03	05	06	07	08	09	10	11	12
$T_{2N}$	02/03 07	20 °C	[Nm]	0.5	0.75	1.5	3	7 21	15 45	30 90	65 195	130 390	250	500
$P_{20}$	02 brake	20 °C	[W]	6	6	8	10	12	16	21	28	38	50	65
	03/07 clutch	20 °C		6	6	8	10	15	20	28	35	50	68	85
<b>J</b>														
<b>Armature</b>	110/210/610/710/810		[10 <sup>-4</sup> kgm <sup>2</sup> ]	0.010	0.014	0.045	0.122	0.366	1.07	3.72	10.6	40	115	311
	120/130/230/630/730			0.013	0.021	0.068	0.18	0.53	1.57	5.29	15.1	50.1	159	437
	320							0.82	2.6	10.3	27	101		
	170							0.99	2.7	9.12	25.4	88.9	272	814
<b>Rotor</b>	110/130/140/170/610			0.025	0.035	0.15	0.375	0.825	2.38	7.25	21.9	67.4	200	450
	630/640													
	210/230/240/710/730/740 810			0.027	0.038	0.17	0.4	0.9 1.02	2.6 3.05	8 8.76	24 26	73 82.5	220 230	500 520
$W_{Rmax.}$	02/03		[10 <sup>4</sup> J]	0.04	0.05	0.08	0.12	0.19	0.31	0.48	0.75	1.25	2	2.9
$W_{R0.1mm}$	02/03		[10 <sup>7</sup> J]	0.23	0.3	0.43	0.63	0.95	1.63	2.53	4.09	6.66	10.4	16.3
$P_{Rmax.}$	02 brake		[J/s]	12.8	18.6	26.9	38.9	58.3	79.2	114	164	236	339	489
	03 clutch			20.3	28.6	40.6	58.3	80.6	114	161	228	322	458	647
$X_{nmax.}$ 20°	02/03 07		[mm]	0.3	0.45	0.45	0.6	0.7 0.15	0.7 0.2	0.7 0.2	0.9 0.2	1.0 0.25	1.2	1.2
<b>X</b>	02/03			0.1	0.15	0.15	0.2	0.2	0.2	0.2	0.3	0.3	0.4	0.4
$n_{max.}$	02/03/07		[rpm]	10,000	10,000	10,000	10,000	8,000	6,000	5,000	4,000	3,000	3,000	2,000
	<b>EXCEPTION CLUTCH!</b> <b>03.610/630/640</b>			1,500	1,500	1,500	1,500	1,500	1,500					
<b>Switching times</b>														
<b>Brake 02</b>	$t_2$ DC	[ms]	3	4	5	8	10	15	50	85	100	140	200	
			$t_2$ AC	17	20	25	40	70	95	240	300	400	600	800
	nominal voltage	$t_{11} =$	2	3	3	5	6	8	10	13	15	23	35	
			$t_1 =$	5	8	8	17	24	38	42	48	85	118	155
	3 x nominal voltage	$t_{11} =$	1	2	2	3	3	4	5	6	8	10	16	
			$t_1 =$	3	4	4	8	11	17	20	22	38	50	76
<b>Clutch 03</b>	$t_2$ DC	[ms]	5	6	7	10	14	19	40	68	100	130	200	
			$t_2$ AC	17	19	22	30	39	61	115	220	400	650	900
	nominal voltage	$t_{11} =$	4	5	7	10	14	18	23	25	29	37	55	
			$t_1 =$	10	14	17	32	48	74	81	90	161	201	295
	3 x nominal voltage	$t_{11} =$	2	2	3	5	6	8	10	12	14	16	25	
			$t_1 =$	5	6	7	16	22	33	37	42	69	91	125

## LEGEND

$T_{2N}$	rated torque after running in process	[Nm]	$t$	time	[ms]
$T_{erf}$	required torque	[Nm]	$t_1$	<b>Engaging time:</b> Time from connecting the current until 0,9 x $T_{2N}$ is attained	[ms]
$J$	moment of inertia	[10 <sup>-4</sup> kgm <sup>2</sup> ]	$t_{11}$	<b>Engaging delay time:</b> Time from connecting the current until the torque rises	[ms]
$P_{20}$	power at 20 °C	[W]	$t_2$	<b>Release time:</b> Time from disconnecting the current until 0.1 $T_{2N}$	[ms]
$n_{max}$	maximum speed	[rpm]			
$X$	rated air gap	[mm]			
$X_n$	clearance at which an adjustment is recommended	[mm]			
$W_{Rmax}$	permissible friction per switching operation	[10 <sup>4</sup> J]			
$W_{R0.1}$	friction work up to 0,1 mm wear	[10 <sup>7</sup> J]			
$P_{Rmax}$	permissible friction work per second	[J/s]			
$I$	magnet-rated current	[A]			



## DC-SIDE SWITCHING

### Current / time and torque / time diagrams

The mentioned designations of switching times are according to DIN VDE 580. The specified switching times are achieved with adjusted nominal air gap ( $x_{min}$ ). It concerns average values whose scattering depends on the current supply and the coil temperature. The torques specified in the measuring tables are safely achieved with single-side clutches and brakes after a run-in phase at 100 rpm. In new condition and in case of substantially higher speeds the torques are possibly smaller.

## CURRENT SUPPLY

The COMBINORM requires a DC voltage, which can be made available by different rectifiers, transformer rectifiers as well as electronic switches of the serie COMBITRON 91. A short-time overvoltage produces very short switching times and high switching accuracies.

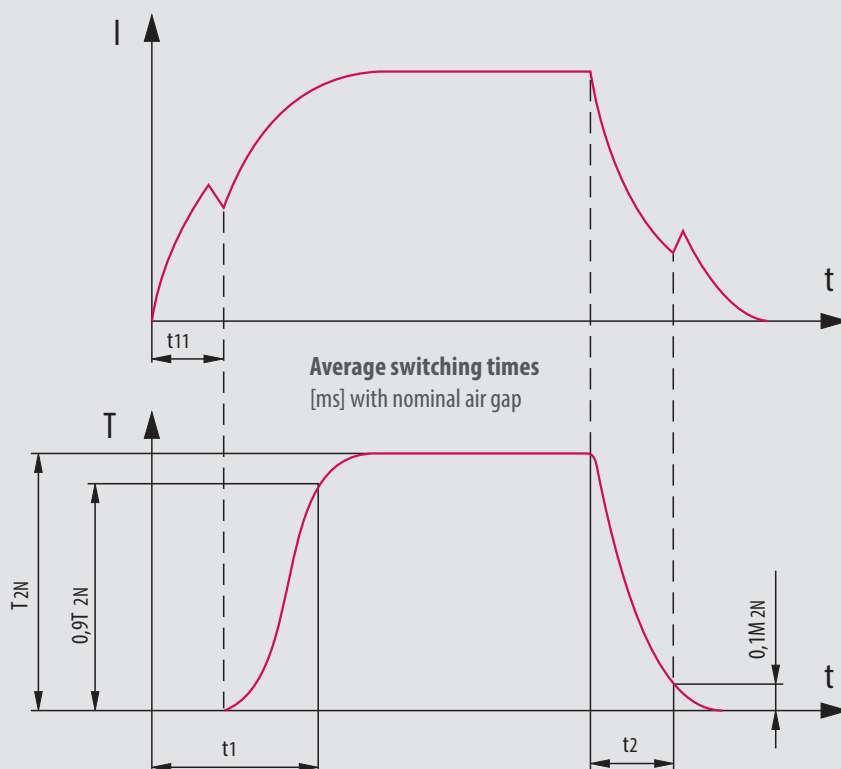

# COMBIBOX PROGRAM SCHEDULE

## COMBIBOX CLUTCH-BRAKE-COMBINATION TYPE 10 / 09 / 06

with an energised to engage single sided clutch / brake

COMBIBOX 10

with an energised to engage single sided clutch without brake

COMBIBOX 09

with an energised to engage single sides clutch / and energised to disengage single sided permanent magnet brake

COMBIBOX 06

### TECHNICAL DATA

COMBIBOX shaft in / shaft out

page 36

COMBIBOX bore in / bore out

page 37

COMBIBOX bore in / shaft out

page 38

COMBIBOX shaft in / bore out

page 39

Moments of inertia, friction work and calculations

page 40

On request we adapt the COMBIBOX to your constructional and electrical requirements.

### DESIGN ATTACHMENTS

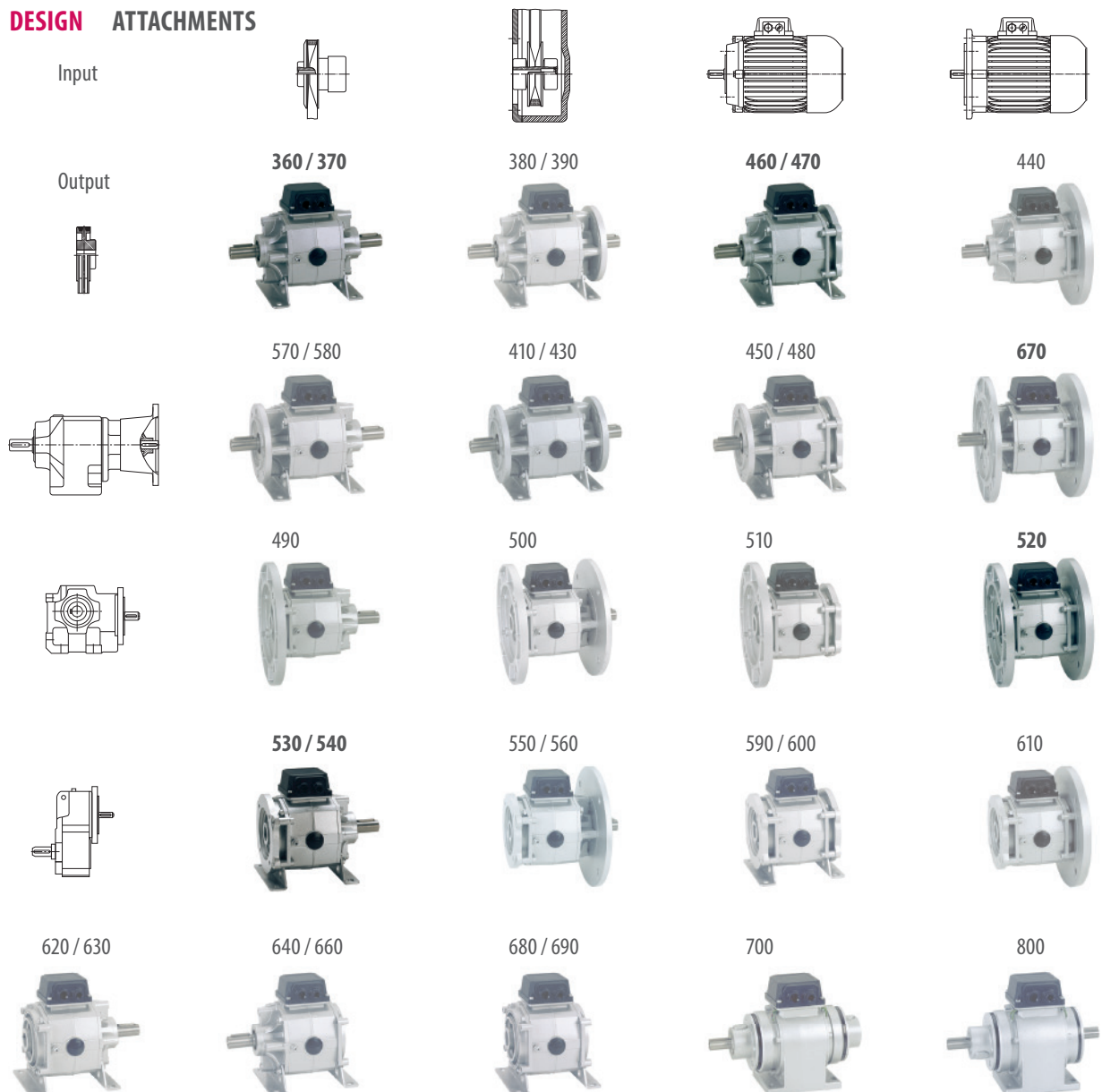

The COMBIBOX is a ready to install electromagnetic actuated clutch-brake module in a single housing.

The modular system is designed for a multitude of variants; these covering most of the applications in the field. The patented adjustment procedure permits an air gap readjustment in it's installed condition. Thus giving a greater lifetime of the wear affected components.

The units designed for Start-Stop-operation considerably reduce the energy consumption due to a continuously running drive.

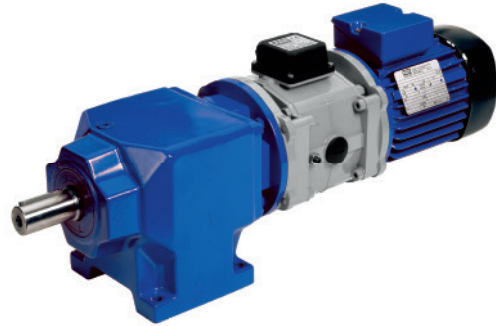

## TYPE 10

has an energise to engage single sided brake, this is the most commonly used, permitting high switching frequency and good positioning accuracy. The COMBITRON rapid switch can be used with this variant to achieve exceptionally high switching frequencies. The rated torque of both clutch and brake are identical.

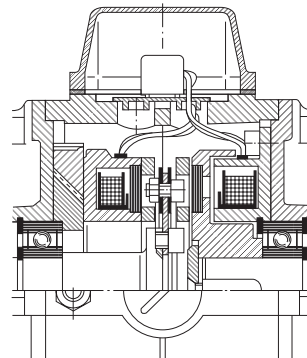

## TYPE 09

is the COMBIBOX version without brake, i.e. an electrical clutch in a housing for the use between e.g. motor and gear unit.

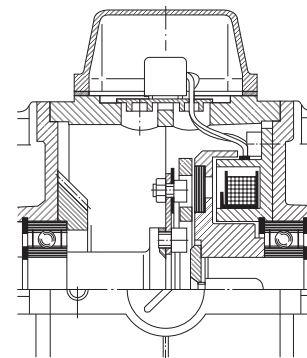

## TYPE 06

has an energise to disengage permanent magnet single-side brake. The characteristic of this variant is that the position of the output shaft is kept safe and backlash-free in currentless condition. The rated torque of the brake is slightly lower than that of the clutch.

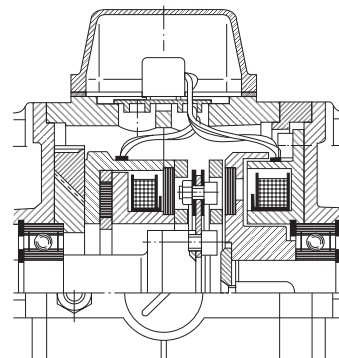

# COMBIBOX SHAFT IN / SHAFT OUT

SIZE	a <sub>3</sub>	a <sub>4</sub>	a <sub>7</sub>	b	c	e	f <sub>2</sub>	f <sub>5</sub>	g	h	h <sub>1</sub>	i	k	k <sub>1</sub>	n	s	s <sub>2</sub>	u	Shaft		Weight [kg]
																			d <sub>1</sub>	l	
06	80	100/109	85	115/124	3	72	100	10	103	63	87	18.4	137/146	117/126	18	7	M6	44	11 14	23 30	2.8/2.9
07	105	115/125	110	138/148	3	90	130	10	125	71	94	22.7	160/170	140/150	25	9	M8	50	14 19	30 40	3.9/4.1
08	130	135/147	140	160/172	4	112	160	12	158	90	108	30.6	196/208	172/184	28	9	M8	62	19 24	40 50	7.7/8.7
09	150	155/169	160	180/194	5	137	180	14	185	100	129	34.4	224/238	196/210	30	11	M10	74	24 28	50 60	12.5/15.0
10	185	185/202	195	215/232	6	175	223	18	236	132	154	50.6	286/303	250/267	38	13	M12	95	28	60	22.5/28.0
11	upon request																				

Alle dimensions in mm keyways according to DIN 6885/1 centerings D according DIN 332/2 standard voltage 24 V DC VDE 0580, ISO-class „B“

## Rated torques type 10 / 09 / 06

SIZE		06	07	08	09	10	11
T <sub>2N</sub> <sup>1)</sup> [Nm]	clutch	7	15	30	65	130	250 / -
	brake	7 / 6	15 / 12	30 / 24	65 / 50	130 / 120	250 / -
P <sub>20</sub> [W]	clutch	15	20	28	35	50	68 / -
	brake	12 / 13	16 / 21	21 / 20	28 / 30	38 / 50	50 / -

<sup>1)</sup> rated torque after running in process

variations type 06 (marked in red)

## PART NO.

	feet	input flange B5 (1)	output flange B5 (1)
-----360			
-----370	X		
-----380		X	
-----390	X	X	
-----410		X	X
-----430	X	X	X
-----570			X
-----580	X		X

Design  
Type  
Size

## ORDERING EXAMPLE:

Size **06** **10** **430** Design  
Type  
V DC, Ø a<sub>r</sub>, Ø d<sub>1</sub> ?

## Ordering specification:

- part number
- diameter of input-side flange
- diameter of input-side shaft
- diameter of output-side shaft
- diameter of output-side flange
- operating voltage of COMBIBOX
- flange dimensions on page 41

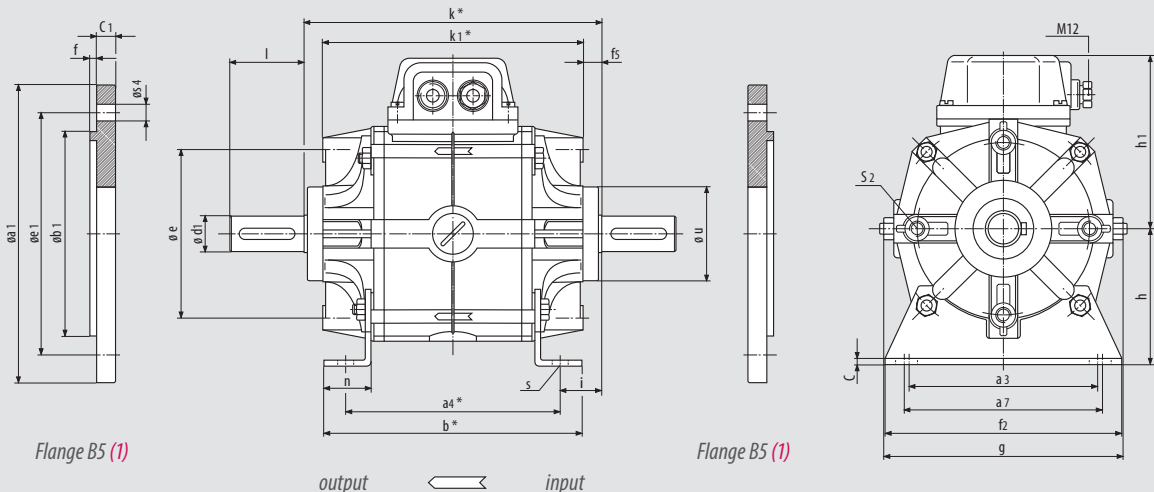

Flange dimensions page 41

SIZE	a <sub>3</sub>	a <sub>4</sub>	a <sub>5</sub>	a <sub>7</sub>	b	b <sub>4</sub> h8	c	d <sub>2</sub> G7 <sub>max</sub>	d <sub>3</sub> G7 <sub>max</sub>	e <sub>3</sub>	f <sub>2</sub>	f <sub>6</sub>			Preferential-bore d <sub>2</sub> and d <sub>3</sub>
06	80	100/109	104	85	115/124	60	3	15	15	108	100	4			11 or 14
07	105	115/125	123	110	138/148	70	3	24	24	128	130	4			14 or 19
08	130	135/147	155	140	160/172	80	4	28	28	165	160	4			19 or 24
09	150	155/169	178	160	180/194	95	5	35	35	190	180	5			24 or 28
10	185	185/202	229	195	215/232	110	6	42	42	242	223	5			28
11	upon request														

All dimensions in mm keyways according to DIN 6885/1 centerings D according to DIN 332/2 standard voltage 24 V DC VDE 0580, ISO-class „B“

SIZE	g	h	h <sub>1</sub>	k <sub>4</sub>	l <sub>1</sub>	l <sub>2</sub>	l <sub>3</sub>	n	s	s <sub>6</sub>	v	a			Weight [kg]
06	103	63	87	101 / 110	50	57	9	18	7	5.5	30	60			2.7 / 3.1
07	125	71	94	108 / 118	52	61	9	25	9	6.5	35	60			3.7 / 4.5
08	158	90	108	132 / 144	63.5	75	11	28	9	8.5	45	64			7.5 / 8.9
09	185	100	129	153 / 167	74	86	13	30	11	8.5	50	62			12.0 / 14.5
10	236	132	154	175 / 192	86	102	17	38	13	10.5	70	60			20 / 25.5
11	upon request														

variations type 06 (marked in red) <sup>1)</sup> rated torque after running in process

PART NO.	feet	input flange		outout flange	
		B5 (2)	B14 (3)	B5 (2)	B14 (3)
-----510			X	X	
-----520		X		X	
-----590			X		X
-----600	X		X		X
-----610		X			X
-----680					
-----690	X				

### ORDERING EXAMPLE:

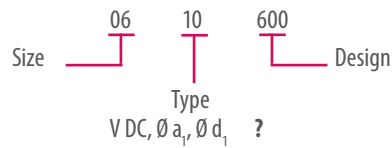

### Ordering specification:

- part number
- diameter of input-side flange
- diameter of input-side bore
- diameter of output-side bore
- diameter of output-side flange
- operating voltage of COMBIBOX
- flange dimensions on page 41

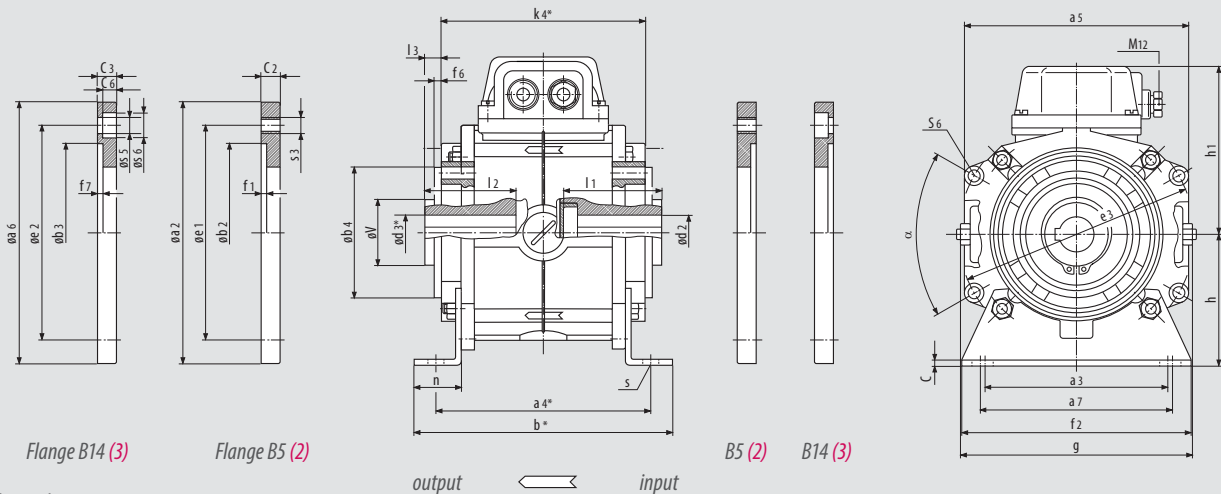

Flange dimensions page 41

# COMBIBOX BORE IN / SHAFT OUT

## SIZE

	a <sub>3</sub>	a <sub>4</sub>	a <sub>5</sub>	a <sub>7</sub>	b	b <sub>4</sub> h8	c	d <sub>2+3</sub> G7 max	e	e <sub>3</sub>	f <sub>2</sub>	f <sub>5</sub>	f <sub>6</sub>	g	h
06	80	100/109	104	85	115/124	60	3	15	72	108	100	10	4	103	63
07	105	115/125	123	110	138/148	70	3	24	90	128	130	10	4	125	71
08	130	135/147	155	140	160/172	80	4	28	112	165	160	12	4	158	90
09	150	155/169	178	160	180/194	95	5	35	137	190	180	14	5	185	100
10	185	185/202	229	195	215/232	110	6	42	175	242	223	18	5	236	132
11	upon request														

Alle dimensions in mm keyways according to DIN 6885/1 centerings D according DIN 332/2 standard voltage 24 V DC VDE 0580, ISO-class „B“

## Rated torques type 10 / 09 / 06

SIZE		06	07	08	09	10	11
T <sub>2N</sub> <sup>1)</sup> [Nm]	Clutch	7	15	30	65	130	250 / -
	Brake	7 / 6	15 / 12	30 / 24	65 / 50	130 / 120	250 / -
P <sub>20</sub> [W]	Clutch	15	20	28	35	50	68 / -
	Brake	12 / 13	16 / 21	21 / 20	28 / 30	38 / 50	50 / -

variations type 06 (marked in red) <sup>1)</sup> rated torque after running in process

## PART NO.

Part No.	feet	input flange		output flange B5 (1)
		B5 (2)	B14 (3)	
440		X		
450			X	X
460			X	
470	X		X	
480	X		X	X
640				
660	X			
670		X		X



Design  
Type  
Size

## ORDERING EXAMPLE:

Size **06** **10** **450** Design  
Type  
V DC, ø a<sub>6</sub>, ø a<sub>r</sub>, ø d<sub>1</sub> ?

## Ordering specification:

- part number
- diameter of input-side flange
- diameter of input-side bore
- diameter of output-side shaft
- diameter of output-side flange
- operating voltage of COMBIBOX
- flange dimensions on page 41

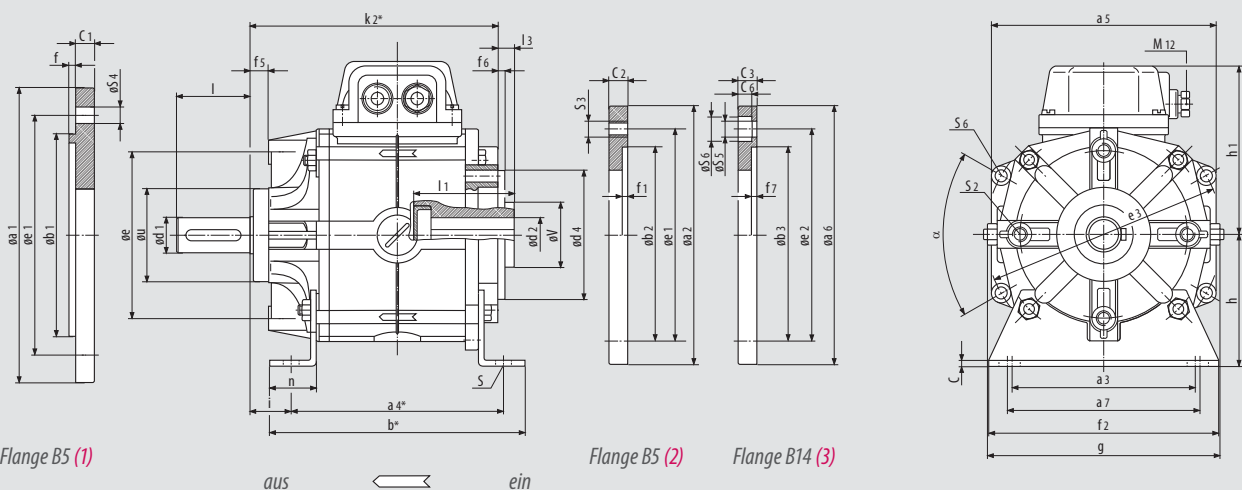

Flange B5 (1)

Flange dimensions page 41

h <sub>1</sub>	i	k <sub>2</sub>	l <sub>1</sub>	l <sub>3</sub>	n	s	s <sub>2</sub>	s <sub>6</sub>	u h8	v	α	Preferential-bore	Shaft		Weight [kg]
												d <sub>2</sub> and d <sub>3</sub>	d <sub>1</sub> k6	l	
87	18.4	119/128	50	9	18	7	M6	5.5	44	30	60	11 or 14	11 14	23 30	2.8/3.1
94	22.7	134/144	52	9	25	9	M8	6.5	50	35	60	14 or 19	14 19	30 40	3.9/4.5
108	30.6	164/176	63.5	11	28	9	M8	8.5	62	45	64	19 or 24	19 24	40 50	7.7/8.9
129	34.4	189/203	74	13	30	11	M10	8.5	74	50	62	24 or 28	24 28	50 60	12.5/14.5
154	50.6	231/248	86	17	38	13	M12	10.5	95	70	60	28	28	60	22.5/26.0

Alle dimensions in mm keyways according to DIN 6885/1 centerings D according DIN 332/2 standard voltage 24 V DC VDE 0580, ISO-class „B“ variations type 06 (marked in red) <sup>1)</sup> rated torque after running in process

ARTIKELNUMMER	feet	input flange B5 (1)	output flange B5 (2) B14 (3)
-----490			X X
-----500		X	X
-----530			X X
-----540	X		X X
-----550		X	X
-----560	X	X	X
-----620			
-----630	X		

Design  
Type  
Size

### ORDERING EXAMPLE:

Size 06 10 500 Design  
Type  
V DC, Ø a1, Ø d1, Ø a2, Ø d3 ?

### Ordering specification:

- part number
- diameter of input-side flange
- diameter of input-side shaft
- diameter of output-side bore
- diameter of output-side flange
- operating voltage of COMBIBOX
- flange dimensions on page 41

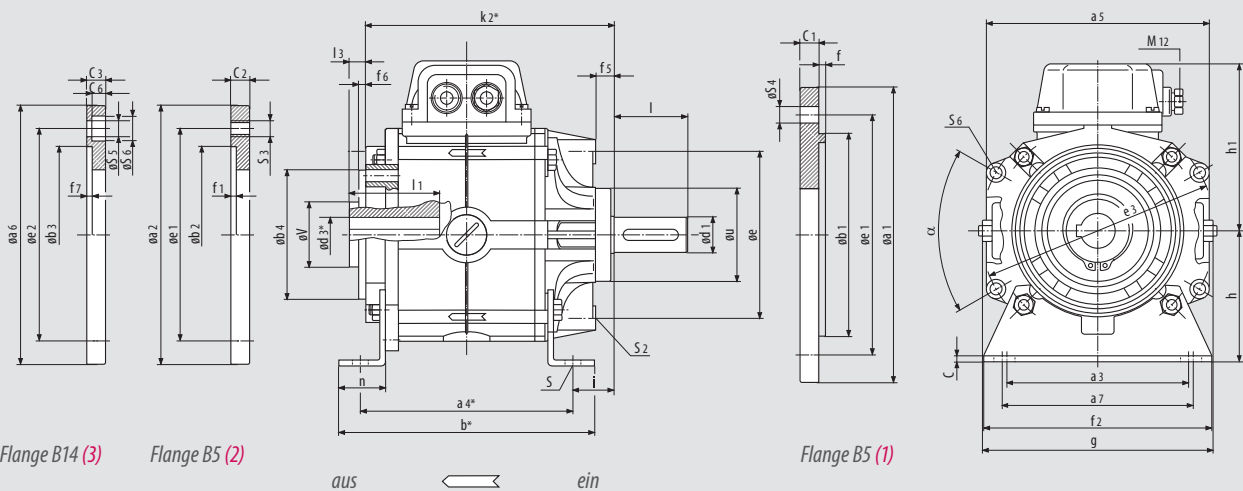

Flange dimensions page 41

# COMBIBOX TECHNICAL DATA

COMBIBOX 06 / 09 / 10				06	07	08	09	10	11
Size	Type	Type							
$T_{2N}^{2)}$	Clutch	06/09/10	[Nm]	7	15	30	65	130	250
	Brake	10		7	15	30	65	130	250
		06			6	12	24	50	120
$P_{20}$	Clutch	06/09/10	[W]	15	20	28	35	50	68
	Brake	10		12	16	21	28	38	50
		06			13	21	20	30	50
$J^{1)}$	Rotor	06/09/10	$[10^{-4}kgm^2]$	1.07	2.98	7.78	23.29	67.4	220
	Armature	06/10		0.84	2.62	8.59	23.08	91.07	330
	Armature	09		0.80	1.2	4.8	12.61	54.3	190
$W_{Rmax}$		06/09/10	$[10^3J]$	1.9	3.1	4.8	7.5	12.5	20.0
$W_{R0.1mm}$	Clutch	06/09/10	$[10^6J]$	9.5	16.3	25.3	40.9	66.6	104
	Brake	06/10		9.5	16.3	25.3	40.9	66.6	104
$P_{Rmax.}$	Clutch	06/09/10	[J/s]	81	114	161	228	323	458
	Brake	06/10		59	80	114	164	236	339
X		06/09/10	[mm]	0.2	0.3	0.35	0.35	0.4	0.5
$X_n$		06/09/10	[mm]	0.4	0.6	0.7	0.7	0.8	1.0
$n_{max}$		06/09/10	[rpm]	3,000	3,000	3,000	3,000	3,000	3,000

## SWITCHING TIMES

		Type 09/10 rated voltage [ms]				Type 06 rated voltage [ms]			
Clutch		$t_{11}$	$t_1$	$t_2$		$t_{11}$	$t_1$	$t_2$	
Brake		$t_2$		$t_{11}$	$t_1$	$t_{11}$		$t_2$	$t_1$
Size	06	18	55	15	45	20	50	10	45
	07	25	95	20	60	25	85	14	50
	08	40	125	30	110	40	100	22	68
	09	50	200	40	160	50	200	30	150
	10	60	250	45	220	85	250	40	180
	11	100	300	80	260				

$J^{1)}$	= moment of inertia	[kgm <sup>2</sup> ]	$t_1$	= Engaging time, time until 0.9 $T_{2N}$ is reached	[ms]
$T_{2N}^{2)}$	= rated torque after running in process	[Nm]			
PR	= permissible friction per second	[J/s]			
P20	= power input at 20 °C	[W]	$t_{11}$	= Engaging delay time, time until the armature is attracted	[ms]
WR	= friction	[J]			
WR0.1	= friction work until an abrasion of 0,1 mm is reached	[J]			
X	= rated air gap	[mm]	$t_2$	= Release time, time until the armature is attracted to the opposing side.	[ms]
$X_n$	= clearance at which a readjustment is recommende	[mm]			

<sup>1)</sup> Sum of the moment of inertia reduced to the speed of the COMBIBOX plus the moment of inertia of the COMBIBOX parts to be accelerated or decelerated (J).

<sup>2)</sup> The rated torques listed are safely attained after a run-in phase at 100 rpm. In new condition and for substantially higher speeds the torques are possibly lower.

## POWER SUPPLY

COMBIBOX requires d.c. voltage for actuation. The rated voltage of the magnets is 24 V DC standard. For operation with rectifiers the magnets are available in other voltages on specification. The permanent-magnet brake installed in type 06 requires a smoothed supply voltage. To ensure a safe function in case of large temperature fluctuations, we recommend the supply of the coil with constant current.



# COMBIBOX FLANGE DIMENSIONS

SIZE	IEC Ø <sup>1)</sup>	a1 (1)	a2 (2)	a6 (3)	b1 (1) h8	b2 (2) +0.3 +0.2	b3 (3) H8	c1 (1)	c2 (2)	c3 (3)	c6 (3)
06	90	90	105	105	60	60	60	10	10	10	5.5
	105	105	105	105	70	70	70	10	10	10	6.5
	120	120	120	120	80	80	80	10	10	10	6.5
	140	140	140	140	95	95	95	10	10	12	8.0
	160	160	160	160	110	110	110	10	12	12	8.0
07	105	110	120	120	70	70	70	10	10	10	6.5
	120	120	120	120	80	80	80	10	10	10	6.5
	140	140	140	140	95	95	95	10	10	10	6.0
	160	160	160		110	110		10	12		6.0
	200	200	200		130	130		10	14		8.0
08	120	130	-	160	80		80	12		12	6.5
	140	140	160	160	95	95	95	12	12	12	6.0
	160	160	160	160	110	110	110	12	12	12	6.0
	200	200	200	200	130	130	130	12	14	14	7.0
	250	250	250	-	180	180		12	14		
09	140	160	160	160	95	95	95	14	14	14	9.0
	160	160	160	160	110	110	110	14	14	14	9.0
	200	200	200	200	130	130	130	14	14	14	
	250	250	250	250	180	180	180	14	14	14	
10	160	-	200	200		110	110		18	18	9.0
	200	210	200	200	130	130	130	18	18	18	8.0
	250	250	250		180	180		18	18		
	300	300	300		230	230		18	18		
	350	350			250			20			
11	250	250	268		180	180		20	25		
	300	300	300		230	230		20	25		
	350	350	350		250	250		20	25		
SIZE	IEC Ø <sup>1)</sup>	e1 (1+2)	e2 (3)	f (1)	f1 (2)	f7 (3)	s3 (2)	s4 (1)	s5(3)	s6 (3)	Weight (1/2/3) [kg]
06	90	75	75	2.5	3	3	M5	5.5	5.5	10	0.16
	105	85	85	2.5	3.5	3	M6	7.0	6.5	11	0.17
	120	100	100	3	3.5	3.5	M6	6.5	6.5	11	0.2
	140	115	115	3	3.5	3.5	M8	9	8.5	14	0.28
	160	130	130	3.5	4	4	M8	9	8.5	14	0.45
07	105	85	85	2.5	3.5	3	M6	M6	6.5	11	0.21
	120	100	100	3	3.5	3.5	M6	6.5	6.5	11	0.22
	140	115	115	3	3.5	3.5	M8	9	9	14	0.3
	160	130		3.5	4		M8	9		14	0.33
08	200	165		3.5	4		M10	11		18	0.55
	120	100	100	3		3.5		7	6.5	11	0.45
	140	115	115	3	3.5	3.5	M8	9	9	14	0.48
	160	130	130	3.5	4	4	M8	9	9	14	0.5
	200	165	165	3.5	4	4.5	M10	11	14	18	0.8
09	250	215	215	4	4.5		M12	14			1.4
	140	115	115	3		3.5		9	9	15	0.5
	160	130	130	3.5	4	4	M8	9	9	15	0.55
	200	165	165	3.5	4	4	M10	11	11		0.63
	250	215	215	4	4.5	4.5	M12	14	14		0.95
10	200	165	165	4	4.5	4	M10	11	11	18	1.1
	250	215		4	4.5		M12	14			1.2
	300	265		4	5		M12	14			1.25
	350	300		5				18			6.5
11	250	215		4	4.5		M12	14			
	300	265		4	4.5		M12	14			
	350	300		5	5.5		M16	18			

<sup>1)</sup> according DIN IEC 34 standard flange

# COMBITRON PROGRAM SCHEDULE

COMBITRON are supply and actuator modules for the electromagnet clutches and brakes. As power supply for DC- or AC-side switching different single-wave and bridge rectifiers as well as rapid switchgear of the series COMBITRON are available.

The rectifiers correspond to the low voltage regulation 73/231/EWG of the European Union.

## COMBITRON RECTIFIERS AND SWITCHES

Half-wave and bridge rectifiers from	0 ... 720 V AC	page 43	<b>COMBITRON 91</b>
Rapid-switching rectifier (for COMBISTOP)		page 44	<b>COMBITRON 98</b>

## TECHNICAL DATA

Switching mode (AC- / DC-side switching)	page 46
--	---------

COMBITRON 91 are rectifiers for power supply of brakes and clutches. AC voltage supply max 720 V AC for AC or DC side switching conform to the low voltage regulation 72/231 EWG of the European Union.

Harmful electromagnetic interferences arise at the switching of electromagnetic clutches and brakes and other inductive DC consumers. The half-wave rectifier 0291010-CEMV limits these interferences to class A according to EN 55011.

All other rectifiers are not equipped with measurements to suppress radio interference. This has to be taken into consideration for the planning of the interference suppression of the plant or the machine. The user is responsible for meeting the EU machine directive.



$U_{in}$ Switching $U_{vmax}$	275 V AC +0% AC/DC 450 V	500 V AC +0% AC/DC 900 V	600 V AC +0% AC 1000 V	720 V AC +0% AC 1600 V
Half wave <sup>4)</sup> $U_{out} = 0,45 * U_{in}$ $I_N (45^\circ C) = 1,0A$ $I_N (80^\circ C) = 0,5A$	0291010-CE07 <sup>2)</sup> 	0491010-CE07 <sup>3)</sup> 	0591010-CE09 <sup>2)</sup> 	0691010-CE09 <sup>3)</sup> 
Fullwave <sup>4)</sup> $U_{out} = 0,9 * U_{in}$ $I_N (45^\circ C) = 2,0A$ $I_N (80^\circ C) = 1,0A$	0291020-CE07 <sup>2)</sup> 	0491020-CE07 <sup>3)</sup> 		
Half wave with EMC protection <sup>1)</sup> $U_{out} = 0,45 * U_{in}$ $I_N (45^\circ C) = 1,0A$ $I_N (80^\circ C) = 0,5A$	0291010-CEMV <sup>3)</sup> 			

$U_{in}$  maximum input voltage  
 $U_{vmax}$  maximum cut-off voltage  
 $U_{out}$  Output DC voltage  
 AC AC switching  
 DC DC-side switching  
 $I_N (45^\circ C)$  Rated output current at the temperature

### CHARACTERISTICS

- UL - certification (No.: E.308765)
- compact design in a plastic housing
- possible installation into the motor terminal box
- protection against voltage peaks of the switching contacts
- maximal ambient temperature 80 °C

<sup>1)</sup> with internal interference suppression according to EN 55011/ class A

<sup>2)</sup> picture 1 <sup>3)</sup> picture 2

<sup>4)</sup> different values (U, A) when used under UL conditions

Nominal voltage magnet	Coil voltage tolerance	AC voltage supply	Type of rectifier	
	$U_2 (U_{out})$	$U_1 (U_{in})$		
24 V DC				
105 V DC	93 - 118	230 V AC	half wave rectifier	(0291010-CE07)
205 V DC	182 - 230	230 V AC	full wave rectifier	(0291020-CE07)
180 V DC	162 - 198	400 V AC	half wave rectifier	(0491010-CE07)

picture 1

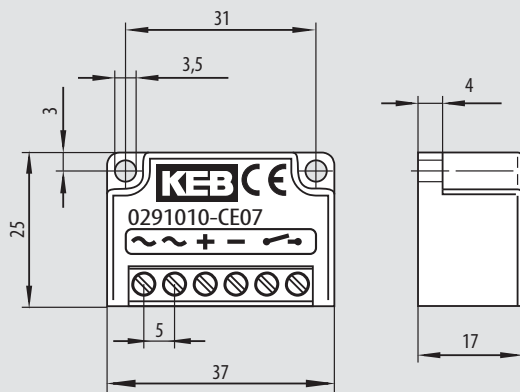

picture 2

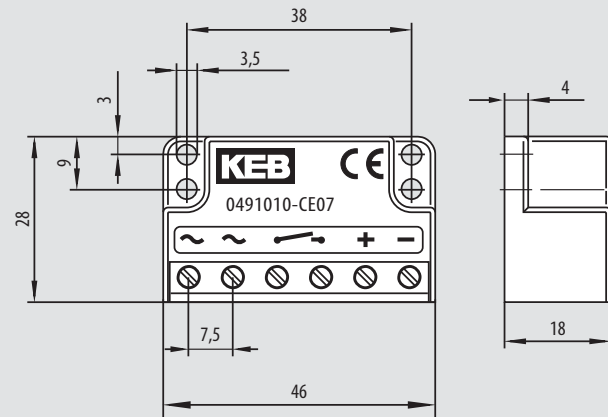

Terminal cross section 1.5 mm<sup>2</sup>

Terminal cross section 2.5 mm<sup>2</sup>

# COMBITRON 98

COMBITRON 98 rapid-switching rectifiers with overexcitation for optimal turn-on and turn-off times of spring-applied brakes and electromagnets. Two Powerbox versions with similar right housing to fit on DIN rail or bolt on version.

COMBITRON 9098200-CE09 UL - certification (No.: E.308765)



	9098210-CE04	9098200-CE09 <sup>1)</sup>
Input voltage	24 V DC $\pm$ 20 %	180-300 V AC $\pm$ 0 %
Overexcitation time	800 ms $\pm$ 15 %	350 ms $\pm$ 10 %
Cable length	max. 10 m to brake coil	max. 100 m to brake coil
Current I <sub>N</sub> 45 °C	1.2 A continous 7 A for 800 ms	1.2 A continous 2.4 A for 350 ms
Current I <sub>N</sub> 75 °C	0.6 A continous 3.5 A for 800 ms	0.7 A continous 1.4 A for 350 ms
Temperature	CCV -40° ... 75°	CCV -40° ... 75°
Switching rate	max. 6 per minute at max current	max. 1 per minute at max current
Side altitude above sea level	> 1,000 m - 1 % current reduction/100 m	> 1,000 m - 1 % current reduction/100 m
Wiring diagrams		

<sup>1)</sup> different values (U, A) when used under conditions of UL

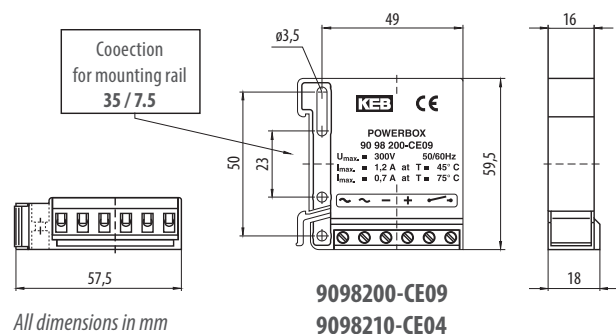

All dimensions in mm



# COMBITRON SWITCHING ARRANGEMENTS

## AC-SIDE SWITCHING

When switching before the rectifier on the AC-side the magnetic field decays slowly. At this mode of switching the tripping delay is quite long. The AC-side switching requires no protective measurements for the coil and the switching contacts. On disconnection the rectifier diodes act as free-wheeling diodes.

The switching times  $t_{11}$  for AC-side switching increase when the rectifier is connected directly in the motor terminal box (2). When the motor slows down a generative voltage is applied to the motor terminals. The wiring (2 and 3) is not permitted for frequency inverter operation.

For line lengths of more than 10 m between rectifier and brake at AC-side switching the regulations prescribe the use of a separate switch (1). In this case the supply voltage may not be tapped behind the motor contactor (2). If it is not possible to install an additional switch the use of special rectifiers becomes necessary.

### CURRENT-TIME-/VOLTAGE-TIME-/ TORQUE-TIME- DIAGRAM

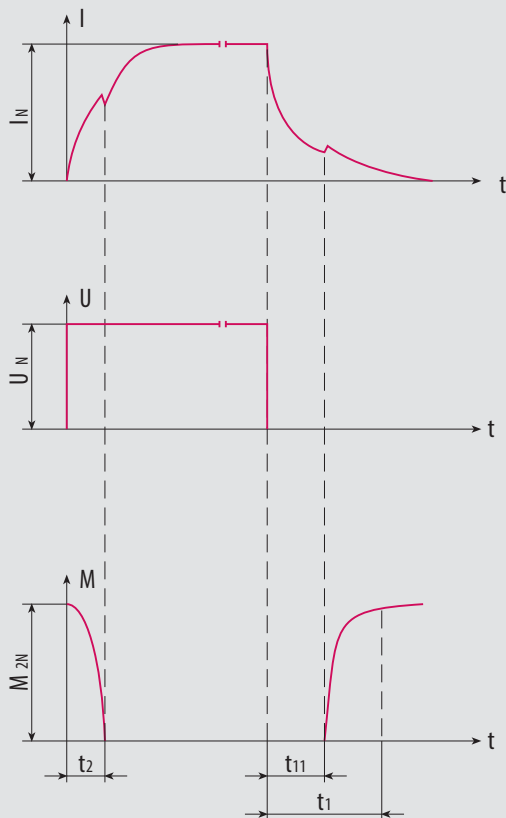

$t_1$  = Engagement time  
 $t_{11}$  = Engagement delay time  
 $t_2$  = Release time

### WIRING DIAGRAM

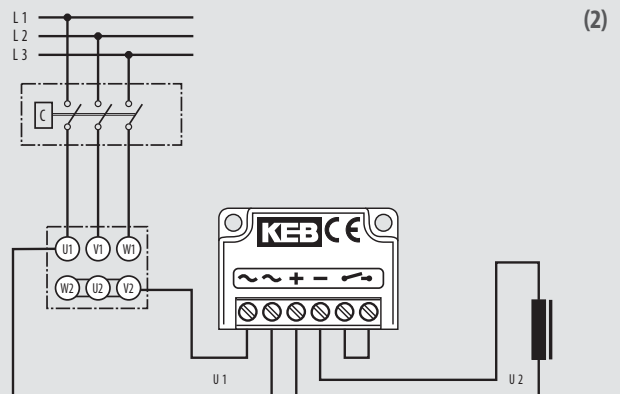
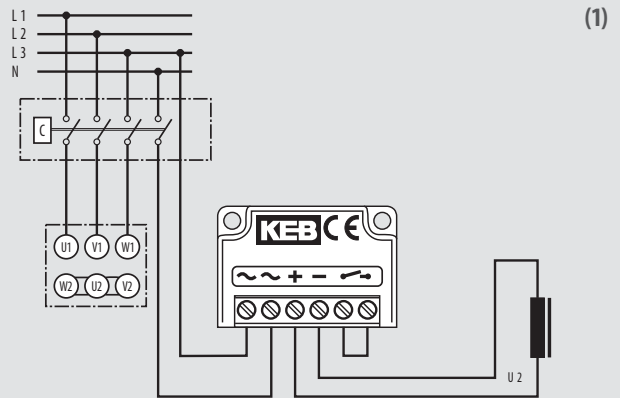

## DC-SIDE SWITCHING

The switching is done between the rectifier and the magnet. At his mode of switching the tripping delay is short, since the energy of the magnetic field is absorbed by the rectifier. The voltage peaks that occur at switching are limited to a harmless level for the rectifier.

The maximal permissible switching frequency for the DC-side switching of rectifiers depends on the energy content of the magnet for COMBISTOP. Higher switching frequencies are achieved by the external connection of a varistor in parallel to the brake or to the terminals + and - DC of the rectifier.

Rectifier	KEB-article	varistor
0291	0090045-2753	S20K275
0491	0090045-6257	S20K625
0591	0090045-6257	S20K625

### CURRENT-TIME-/VOLTAGE-TIME-/ TORQUE-TIME- DIAGRAM

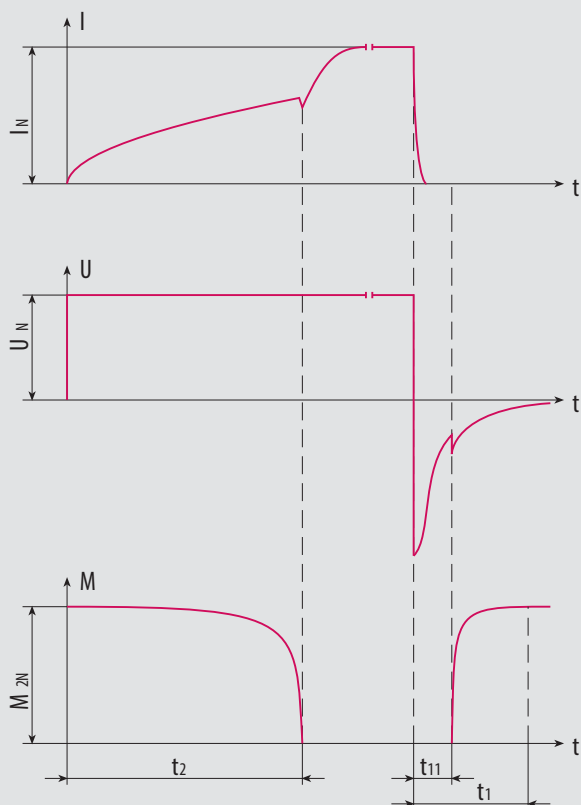

### WIRING DIAGRAM

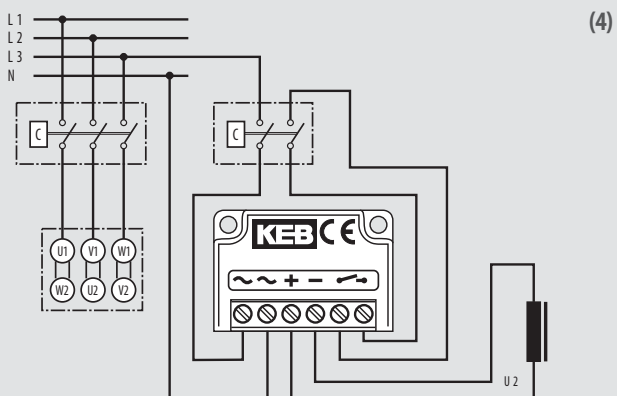
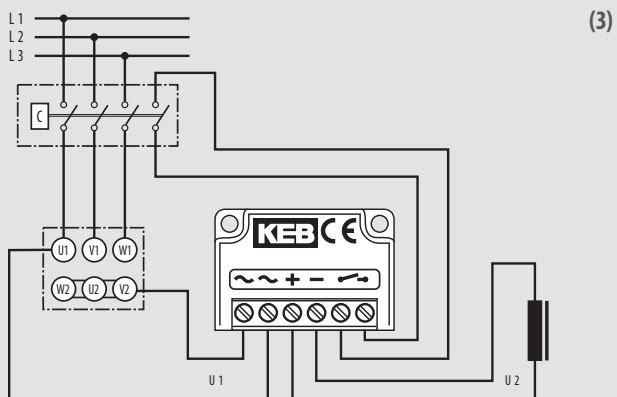

The simultaneous AC and DC-side switching, shown in example 4 guarantees short disconnecting times and reduces the contact erosion.

## DIMENSIONING / CALCULATIONS

Decisive for the dimensioning of the clutches and brakes are the required torque, thermal load, braking time and service life.

### RATED TORQUE $T_{2N}$

To ensure that brakes and clutches work safely even under extreme conditions, the required torque must be multiplied by a safety factor. The selection of the safety factor depends essentially on the application.

The dynamic torque of a single-disc brake may be substantially lower than the rated torque.

$$T_{2N} = T_{\text{erf}} \cdot K \quad K \geq 2 \quad T_{\text{erf}} = \text{required torque [Nm]}$$

### REQUIRED TORQUE $T_{\text{erf}}$

The required torque very often is a mixture of dynamic and static load. When choosing the sign take into account whether the load torque supports or counteracts the deceleration.

$$T_{\text{erf}} = \begin{matrix} T_A \pm T_L \\ T_A = J \cdot \alpha \end{matrix}$$

### ROUGH DEFINITION OF THE REQUIRED BRAKING TORQUE

If the mass moment of inertia is unknown and the driving power is fixed then the required braking torque is calculated as follows:

$$T_{\text{erf}} = 9550 \cdot \frac{P}{n}$$

### THERMAL LOAD

The dimensioning solely on the basis of the required braking torque is permissible only in very few cases. When decelerating the load and the mass moment of inertia is reduced to the brake shaft, the kinetic energy is converted into heat (friction work of the brake). The permissible friction work in dependence on the switching frequency may not be exceeded.

Please note that the maximal permissible friction work is valid only up to the corresponding speed. In case of emergency stop from maximum speed the maximal permissible friction work lies considerably below the values specified in the graphic.

$$W_R = \frac{J \cdot n^2}{182,5} \cdot \frac{T_{2N}}{T_{2N} \pm T_L} \quad WR \leq WR_{\text{max}}$$

### SLIP TIME $t_3$ [MS]

The time from the beginning of the torque rise until attaining the moment of synchronization.

$$t_3 = 104,6 \cdot \frac{J \cdot \Delta n}{T_{2N} \pm T_L}$$

### SERVICE LIFE

The service life depends to a large extent on the peak temperature at braking, which is dependent on the speed, the deceleration time and the current brake torque.

For that reason it is not possible to make universally valid statements with regard to the service life that apply to all operating conditions. Statements to the individual case can be made only when all operating conditions are known. At no time should the friction lining thickness (COMBISTOP) be less than  $g_{\text{min}}$ .

$$L_N = \frac{(X_n - X) \cdot W_{R0,1}}{0,1 \cdot W_R}$$

### ACCELERATION- / DECELERATION TIME

$$t = \frac{J \cdot \omega}{T_{2N} \pm T_L} + t_{11}$$





## BRANCH OF TRADES / APPLICATION

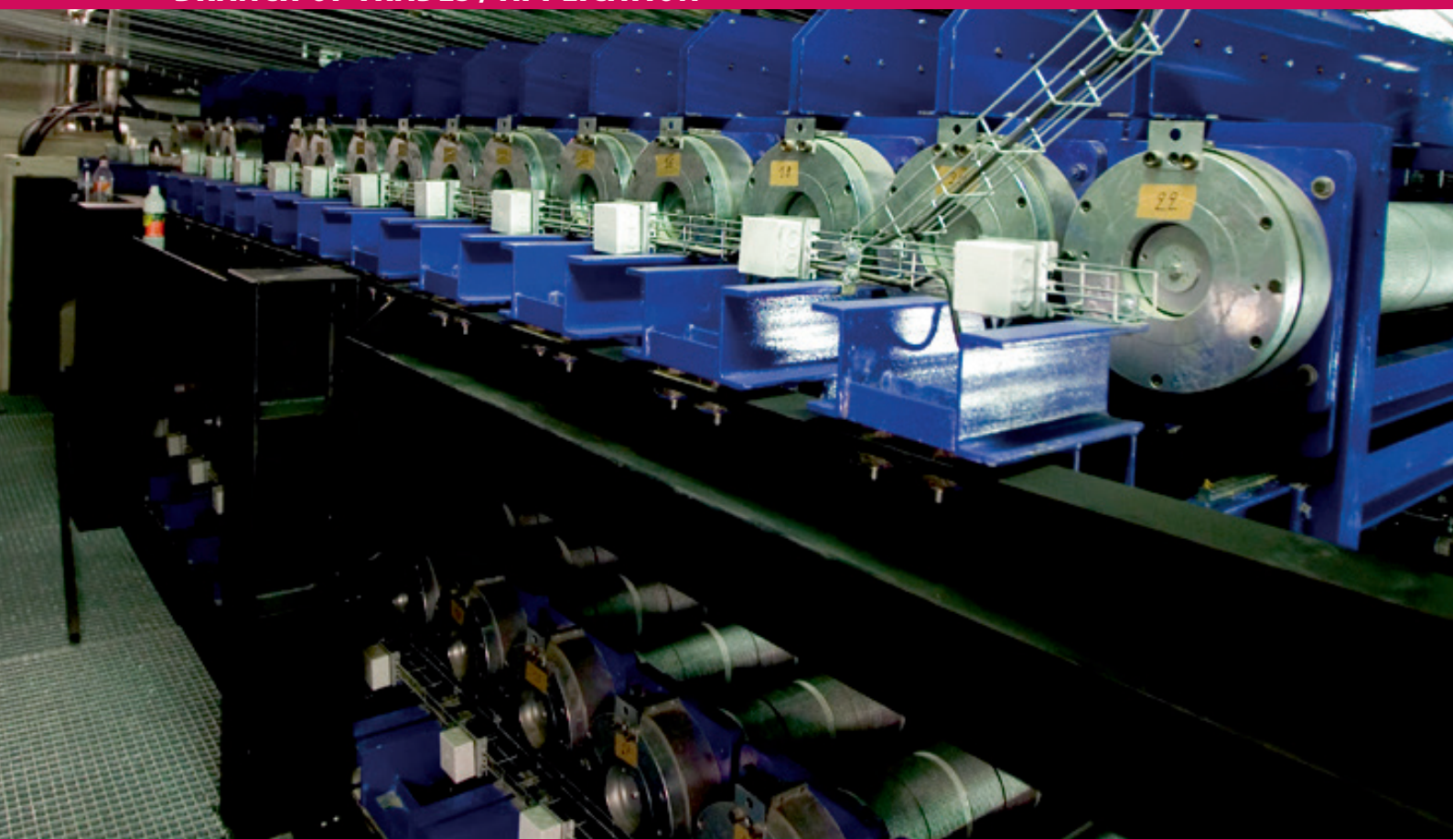

## RELIABLE, SAFE AND ECONOMIC...

Electricity and magnetism are inseparable. Electromagnetism is one of the four elemental forces that can be applied to obtain the maximum power transmission in modern drive technology.

KEB uses this power rationally and selectively to suit the target. Switching machine elements on and off, safe and secure stopping and holding of loads or dynamic positioning, and so on...

Electromagnetic assemblies offer the design engineer economic, robust, safe, secure and reliable options for individual solutions!



### KEY APPLICATIONS FOR MARKET DEVELOPMENT:

- Motors and geared motors
- Agricultural trucks, communal vehicles, industrial truck engineering
- Lifting gear, running gear and cranes, lifts, theatre and stage engineering
- Medical engineering
- Wind turbines

## KEB WORLDWIDE

**Austria** | KEB Automation GmbH  
Ritzstraße 8 4614 Marchtrenk Austria  
Tel: +43 7243 53586-0 Fax: +43 7243 53586-21  
E-Mail: info@keb.at Internet: www.keb.at

**Belgium** | KEB Automation KG  
Herenveld 2 9500 Geraardsbergen Belgium  
Tel: +32 544 37860 Fax: +32 544 37898  
E-Mail: vb.belgien@keb.de Internet: www.keb.de

**Brazil** | KEB South America – Regional Manager  
Rua Dr. Omar Pacheco Souza Riberio, 70  
BR-CEP 13569-430 Portal do Sol, São Carlos Brazil  
Tel: +55 16 31161294 E-Mail: roberto.arias@keb.de

**France** | Société Française KEB SASU  
Z.I. de la Croix St. Nicolas 14, rue Gustave Eiffel  
94510 La Queue en Brie France  
Tel: +33 149620101 Fax: +33 145767495  
E-Mail: info@keb.fr Internet: www.keb.fr

**Germany | Headquarters**  
KEB Automation KG  
Suedstraße 38 32683 Barntrup Germany  
Telefon +49 5263 401-0 Fax +49 5263 401-116  
E-Mail: info@keb.de Internet: www.keb.de

**Germany | Geared Motors**  
KEB Antriebstechnik GmbH  
Wildbacher Straße 5 08289 Schneeberg Germany  
Telefon +49 3772 67-0 Fax +49 3772 67-281  
E-Mail: info@keb-drive.de Internet: www.keb-drive.de

**Italy** | KEB Italia S.r.l. Unipersonale  
Via Newton, 2 20019 Settimo Milanese (Milano) Italia  
Tel: +39 02 3353531 Fax: +39 02 33500790  
E-Mail: info@keb.it Internet: www.keb.it

**Japan** | KEB Japan Ltd.  
15 - 16, 2 - Chome, Takanawa Minato-ku  
Tokyo 108 - 0074 Japan  
Tel: +81 33 445-8515 Fax: +81 33 445-8215  
E-Mail: info@keb.jp Internet: www.keb.jp

**P. R. China** | KEB Power Transmission Technology (Shanghai) Co. Ltd.  
No. 435 QianPu Road Chedun Town Songjiang District  
201611 Shanghai P. R. China  
Tel: +86 21 37746688 Fax: +86 21 37746600  
E-Mail: info@keb.cn Internet: www.keb.cn

**Republic of Korea** | KEB Automation KG  
Room 1709, 415 Missy 2000 725 Su Seo Dong  
Gangnam Gu 135- 757 Seoul Republic of Korea  
Tel: +82 2 6253 6771 Fax: +82 2 6253 6770  
E-Mail: vb.korea@keb.de Internet: www.keb.de

**Russian Federation** | KEB RUS Ltd.  
Lesnaya str, house 30 Dzerzhinsky MO  
140091 Moscow region Russian Federation  
Tel: +7 495 6320217 Fax: +7 495 6320217  
E-Mail: info@keb.ru Internet: www.keb.ru

**Spain** | KEB Automation KG  
c / Mitjer, Nave 8 - Pol. Ind. LA MASIA  
08798 Sant Cugat Sesgarrigues (Barcelona) Spain  
Tel: +34 93 8970268 Fax: +34 93 8992035  
E-Mail: vb.espana@keb.de Internet: www.keb.de

**Switzerland** | KEB Automation AG  
Witzbergstraße 24 8330 Pfaeffikon/ZH Switzerland  
Tel: +41 43 2886060 Fax: +41 43 2886088  
E-Mail: info@keb.ch Internet: www.keb.ch

**United Kingdom** | KEB (UK) Ltd.  
5 Morris Close Park Farm Industrial Estate  
Wellingborough, Northants, NN8 6 XF United Kingdom  
Tel: +44 1933 402220 Fax: +44 1933 400724  
E-Mail: info@keb.co.uk Internet: www.keb.co.uk

**United States** | KEB America, Inc.  
5100 Valley Industrial Blvd. South  
Shakopee, MN 55379 United States  
Tel: +1 952 2241400 Fax: +1 952 2241499  
E-Mail: info@kebameric.com Internet: www.kebameric.com



## KEB PARTNERS WORLDWIDE

... [www.keb.de/contact/contact-worldwide](http://www.keb.de/contact/contact-worldwide)

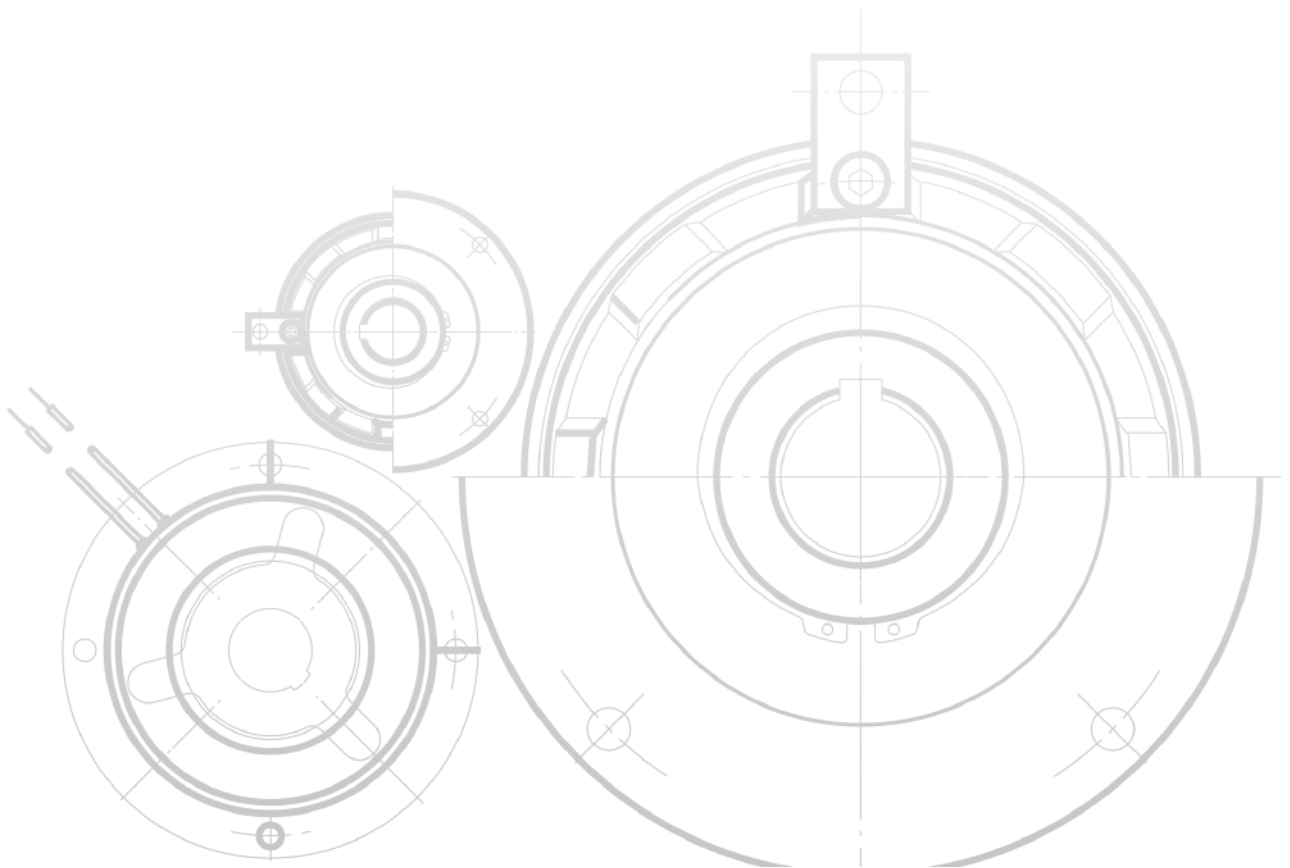

**Automation with Drive**

**[www.keb.de](http://www.keb.de)**

KEB Automation KG Suedstrasse 38 32683 Barntrup Germany Tel. +49 5263 401-0 E-Mail: [info@keb.de](mailto:info@keb.de)

© KEB 0000000-5MAG 05.2019 Subject to technical alterations!