

**KEB**



# DYNAMIC LINE

SERVO MOTORS  
EN



**KEB**

**CONTENTS**

**PAGE**

System description	4
Dynamic Line DL3	6
Planetary gears, Motor- and Encoder cables	8
Dynamic Line DL2	11
Geared servo motors TA	13
Adresses	15

# SYSTEM OVERVIEW

## Automation with Drive

Drive is movement, dynamics, precision, endurance, continuity and much more.

Whether managing formulations, an optimized operator interface or the controlled movement of axes – it all requires a clear overview combined with logic and is based essentially on the selection of the right technology.

The integrated KEB system offers the best basis for high performance and economics in the application as well as excellent efficiency in the practical implementation.

KEB provides the right solutions!

### SOFTWARE

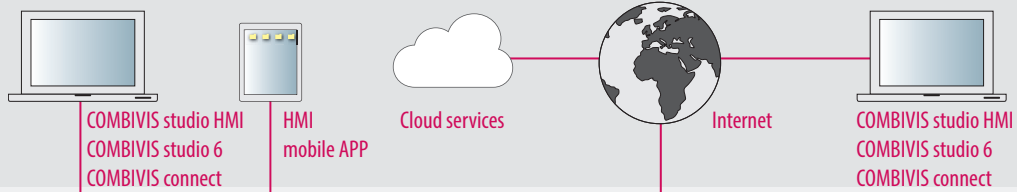

### HMI

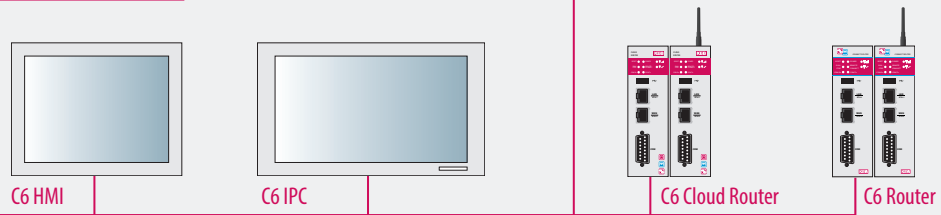

### CONTROL

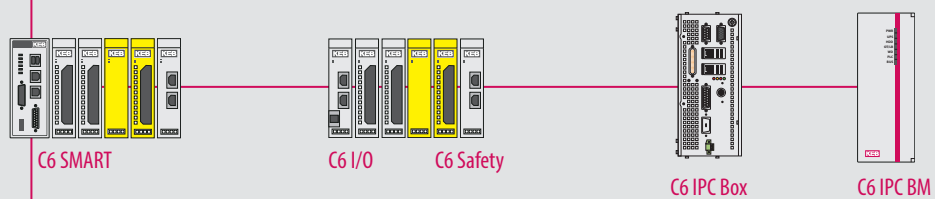

### DRIVES

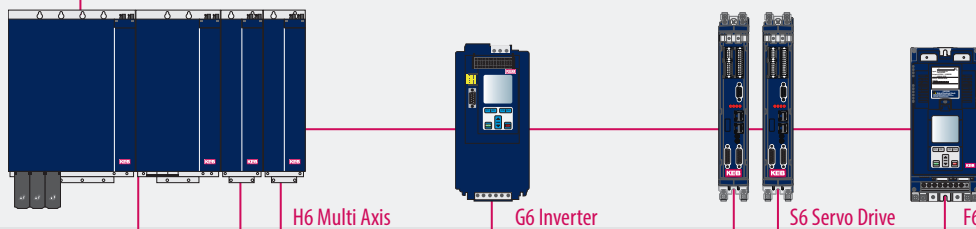

### MOTORS

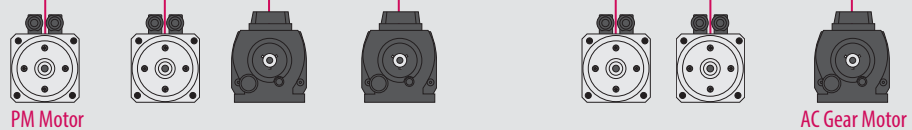

# SERVO MOTORS IN THE COMPLETE SYSTEM

## OPTIMALLY COORDINATED FEATURES – THE KEY TO SUCCESS

From the user interface to the rotating movement – it is our goal to make sure: we provide all the tasks you require from a single supplier. KEB drive controllers have proven themselves in the market for many years. Now we have expanded our range to provide an all-in-one package. The core control function is provided with IPC based control technology, along with software tools, a flexible range for visualisation, and remote maintenance.

Optimum rotating movement is provided by the servo motors, which are available in three series, each with specific benefits. With energy efficiency ratings significantly above IE4 (three-phase asynchronous motors) there is a strong argument in favour of synchronous drive systems. Real time process control is also possible in combination with the COMBIVERT Drive Controller.

The package is complimented with pre-fabricated motor and encoder cables. This allows easy installation, fast start-up and safe operation. Select the right motor for your optimum drive solution from a portfolio that is tailored to meet your specific requirements.



**DYNAMIC LINE DL3** *economical, durable, powerful*



**VERSION STEEL IT** *efficient surface protection*

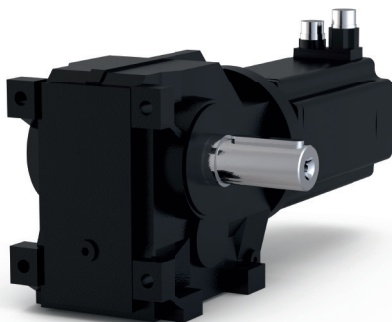

**TA SERIES** *optimized for the geared motor solution*



**DYNAMIC LINE DL2** *for special requirements*

O_SMH	0.2 - 0.5
A_SMH	0.5 - 1.2
B_SMH	1.38 - 3.22
C_SMH	2.45 - 5.65
D_SMH	4.9 - 11.4
E_SMH	12.8 - 29.0
F_SMH	31,8 - 72,6

Stall torque in Nm

### DYNAMIC LINE DL3

With seven physical design sizes and three alternative lengths, this new series covers application areas from the infeed axis to the main drive.

A high degree of density gives excellent peak torques in compact dimensions, whilst built-in modularity offers a flexible solution for the widest verity of tasks. The broad speed range provides the basis for minimal variation and universal use.

Dynamic Line DL 3 series motors create an excellent base for high-performance machines and systems, capable of handling dynamic applications and high loads.



### SPEED-TORQUE CHARACTERISTIC

#### DEFINITION

$T_{d0}$	Stall torque (n=0)
$T_{max}$	max. torque
$T_{dN}$	Rated torque
$n_N$	Rated speed
$n_{max}$	max. speed
$U_{DC}$	DC link voltage

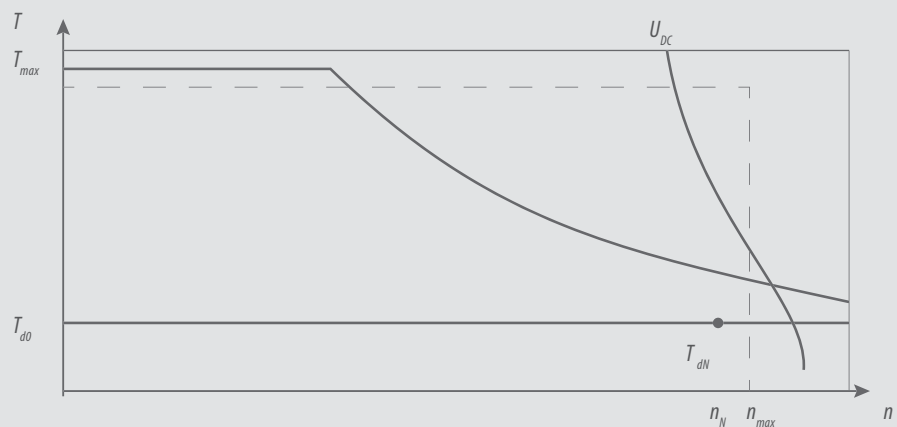

## DYNAMIC LINE DL3

MOTOR	$U_n$ [V]	$T_{dN}$ [Nm]	$T_{d0}$ [Nm]	$T_{max}$ [Nm]	$n_N$ [rpm]	$J_L$ [kgcm <sup>2</sup> ]	A [mm]	B □ [mm]	C (without brake) [mm]	C (with brake) [mm]	$d_{k6}$ ∅ [mm]	L [mm]	$N_{j6}$ ∅ [mm]	P ∅ [mm]	$T_{Brake}$ [Nm]
01SMH		0.18	0.2	0.68		0.029			97	129					
02SMH	230	0.33	0.38	1.37	8,000	0.048	65.4	40	117	149	8	22,5	30	46	0.6
03SMH		0.45	0.52	2.04		0.067			137	169					
A1SMH		0.5	0.5	2.69		0.134			111.5	146					
A2SMH		0.7	0.8	4.18	8,000	0.253	82.5	58	133.5	168	9	20	40	63	2.0
A3SMH		1.0	1.2	6.36		0.373			155.5	190					
B1SMH		1.33	1.38	6.07		0.462			129	168					2.0
B2SMH		2.2	2.37	11.6	6,000	0.842	96.5	72	154	194	14	30	60	75	
B3SMH		2.7	3.22	17.71		1.22			180	229					3.5
C1SMH		2.31	2.45	9.14	6,000	1.08			132	179.5					
C2SMH		3.7	4.1	18.9	5,000	1.98	128.5	87	162	209.5	19	40	80	100	9.0
C3SMH	400	4.9	5.65	29.25	5,000	2.87			192	239.5					
D1SMH		4.4	4.9	17.76	5,000	2.23			136.5	183.5					9.0
D2SMH		6.9	8.2	35.34	4,000	4.06	145.5	104	169.5	216.5	24	50	95	115	
D3SMH		8.35	11.4	53.13	4,000	5.88			202.5	251.5					13.0
E1SMH		11.0	12.8	37.08		13.4			176	228					20.0
E2SMH		15.2	21.1	74.16	3,000	22.3	183.5	142	216	268	32	58	130	165	
E3SMH		13.2	29.0	110.8		34.9			256	315					30.0
F1SMH		19.5	31.8	79.81	3,000	49.6			212	284.5					
F2SMH		38.2	54.8	172.5	2,000	92.3	256	194	269	341.5	38	80	180	215	70.0
F3SMH		38.8	72.6	275.3	2,000	134.9			326	398.5					

### Features:

right angle plug, shaft without keyway,  
KTY-Sensor, protection IP 54 (A ... E)

### Options:

permanent magnet brake,  
shaft with keyway, protection IP65 (A ... E)  
increased surface protection / STEEL IT

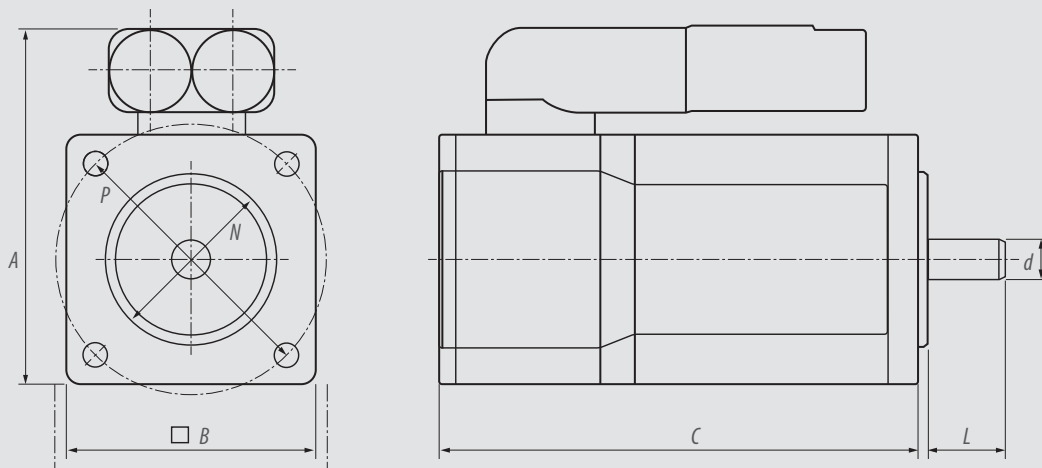

## ENCODER SYSTEMS

Resolver resolution 12 bit/revolution (SAFETY READY)  
 Hiperface Singleturn - 17 bit/revolution\* Multiturn - 12 bit/revolution – 17 bit revolution

Prepared for the operation with: **COMBIVERT S6 COMBIVERT F6 COMBIVERT H6**

## PLANETARY GEARS

SIZE	C Ø [MM]	T <sub>2N</sub> [Nm]	T <sub>2max</sub> [Nm]	n <sub>max</sub> [min <sup>-1</sup> ]	i		backlash arcmin		d <sub>k6</sub> Ø [mm]	N <sub>J6</sub> Ø [mm]	P Ø [mm]	M		DL3 motor size	
					1stufig	2stufig	1stufig	2stufig				1stufig	2stufig		
1	50	5 ... 15	8 ... 24	5,000	5, 10	15,25	< 10	< 12	12	35	44	74.5	87	A	
						15, 25, 40						75	88		
2	70	15 ... 33	24 ... 53	4,500	5, 10	15, 25	< 10	< 12	16	52	62	75	95	B	
						-						92	-		C
						40						101	119		
3	90	38 ... 90	61 ... 144	4,000	5, 10	15	< 7	< 9	22	68	80	111	129	C	
						15, 25						121	139		D
						15, 25, 40						124	151.5		
4	120	95 ... 195	152 ... 312	3,000	5, 10	15, 25	< 7	< 9	32	90	108	134	161.5	D	
						15, 25						149.5	177		E
						25, 40						178.5	223		
5	155	210 ... 460	336 ... 736	2,800	5, 10	25	< 8	< 10	40	120	140	188.5	233	E	

\* upon housing A

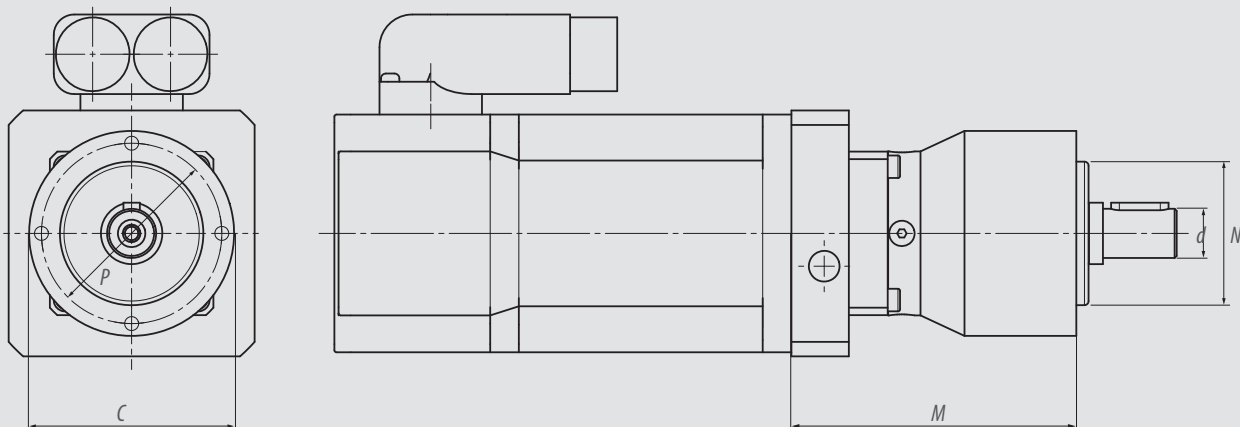

## THE PERFECT CONNECTION

### PLANETARY GEARS SGPP BUNDLED WITH DYNAMIC LINE DL3:

- Low backlash
- High torque
- High efficiency (97%)
- Ratio  $i=5$  up to 40
- Low noise
- Lifetime lubrication
- **Option:** surface protection STEEL IT

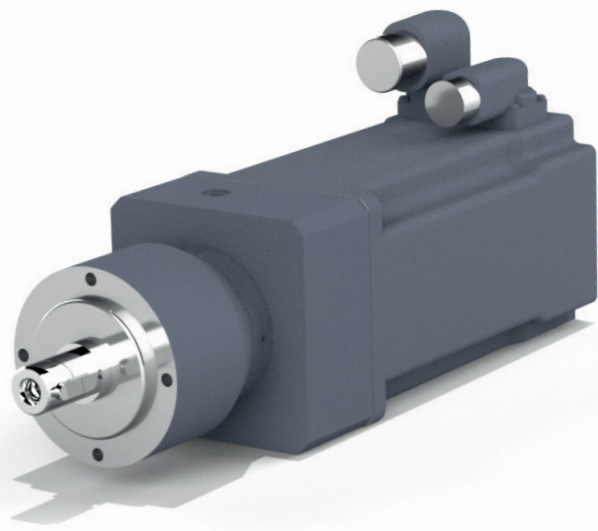

### INDUSTRY SEGMENTS

- Machine tools
- Metal forming
- Packaging technology
- Food technology
- Wood working systems
- General automation devices

### APPLICATION EXAMPLES

- Revolving tables
- Tool changer
- Roboter and handling devices
- Linear positioning
- Conveyor drives
- Winder



## MOTOR CABLES

MOTOR DL3	DRIVE CONTROLLER	PART-NO	AVAILABLE LENGTH [m]
O, A, B SMH	S6 / F6	00H6L10-0xxx	1 ... 30 / 35 ... 50
C ... F SMH		00S4519-0xxx	
<b>MOTOR DL2 / TA</b>			
A ... F SM5	H6	00S4519-0xxx	1 ... 30 / 35 ... 50
A ... F SMT	F5		
TA 1 ... 5			

## ENCODER CABLES

MOTOR DL3	ENCODER	DRIVE CONTROLLER	PART-NO	AVAILABLE LENGTH [m]
A ... F SMH	Resolver	S6 / F6	00S6L50-0xxx	1 ... 30 / 35 ... 50
		H6	00H6L50-0xxx	2.5 / 5 / 7.5 / 10 / 15 ... 50
	Hiperface SKS / SKM	S6 / F6	00S6L55-0xxx	1 ... 30 / 35 ... 50
		H6	00H6L55-0xxx	2.5 / 5 / 7.5 / 10 / 15 ... 50

MOTOR DL2 / TA	ENCODER	DRIVE CONTROLLER	PART-NO	AVAILABLE LENGTH [m]
A ... F SM5	Resolver	S6 / F6	00S6L50-1xxx	1 ... 30 / 35 ... 50
		H6	00H6L50-1xxx	2.5 / 5 / 7.5 / 10 / 15 ... 50
		F5	00F50C1-1xxx	2.5 / 5 / 7.5 / 10 / 15 ... 30
A ... F SMT	BISS	S6 / F6	00S6L51-2xxx	1 ... 30 / 35 ... 50
		H6	00H6L51-2xxx	2.5 / 5 / 7.5 / 10 / 15 ... 50
		F5	00F50C1-Vxxx	2.5 / 5 / 7.5 / 10 / 15 ... 30
	Hiperface SKS / SKM	S6 / F6	00S6L55-1xxx	1 ... 30 / 35 ... 50
		H6	00H6L55-1xxx	2.5 / 5 / 7.5 / 10 / 15 ... 50

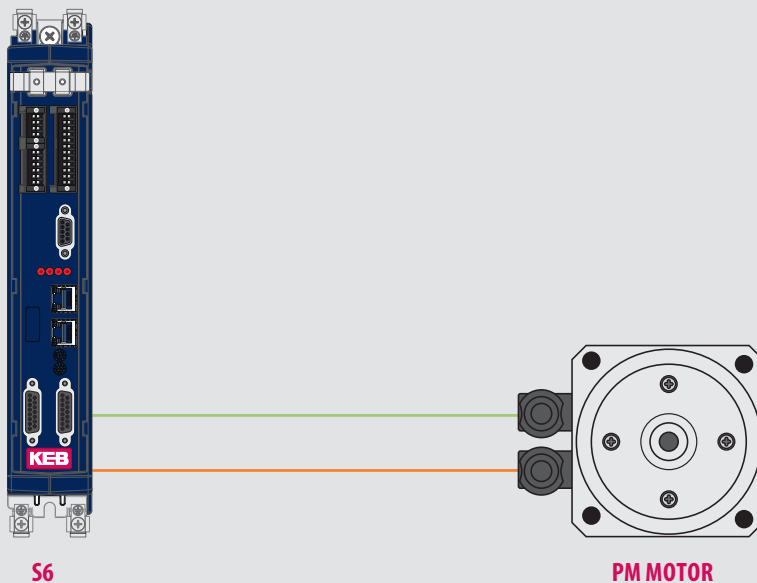

## FOR THE SPECIAL REQUIREMENTS

A_SM5	0.47 – 1.14	
B_SM5	0.92 – 2.6	
C_SM5	3.9 – 8.5	
D_SM5	8.2 – 18.4	
E_SM5	23.5 – 48.0	Stall torque in Nm

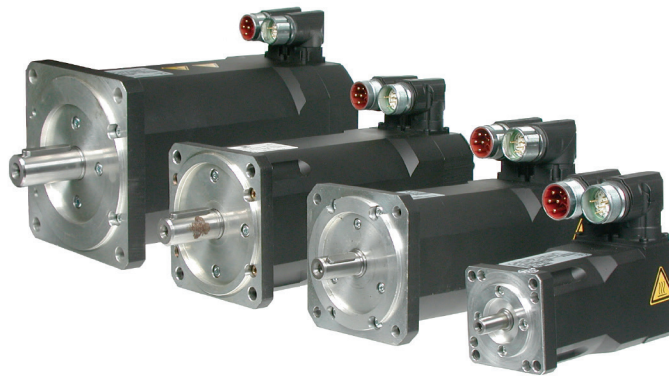

### DYNAMIC LINE 2

This series offers the latest motor technology in five physical design sizes. They have been configured for tasks with a high system resolution, short designs and small build volumes, and are particularly suitable for difficult mechanical conditions such as vibration, installation, location or temperature.

With pre-fabricated cables and an electronic name plate (BISS) the start-up process and potential for error during installation is minimized. The result is a high degree of availability and maximum serviceability.

### SPEED-TORQUE CHARACTERISTIC

#### DEFINITION

$T_{d0}$	Stall torque (n=0)
$T_{max}$	max. torque
$T_{dN}$	Rated torque
$n_N$	Rated speed
$n_{max}$	max. speed
$U_{DC}$	DC link voltage

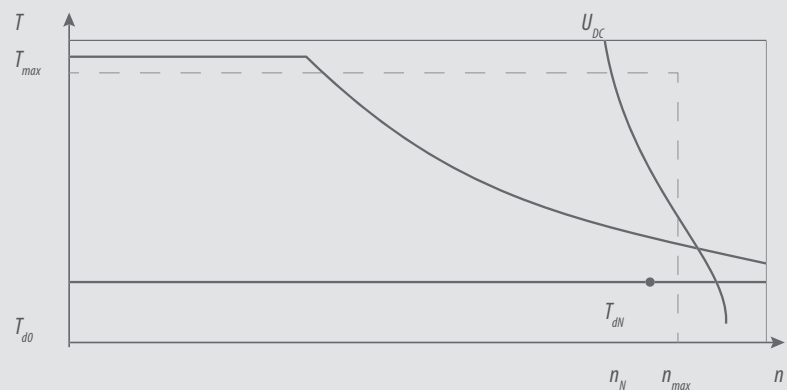

MOTOR	$T_{dN}$	$T_{d0}$	$T_{MAX}$	$n_N$	$J_L$	A	B	C (without brake)		addition	L	$d_{K6}$	$N_{J6}$	P	$T_{BRAKE}$
								resolver	BISS						
	[Nm]	[Nm]	[Nm]	[rpm]	[kgcm <sup>2</sup> ]	[mm]	□ [mm]	[mm]	[mm]	[mm]	[mm]	∅ [mm]	∅ [mm]	∅ [mm]	[Nm]
A1SM5	0.43	0.47	2.1		0.13			121	156	25					
A2SM5	0.62	0.66	2.9	6,000	0.18	99	55	133	168	25	20	9	40	63	2.0
A3SM5	0.8	0.87	3.8		0.23			145	180	25					
A4SM5	1.05	1.14	5.0		0.34			170	205	25					
B1SM5	0.9 / 0.87 / 0.76	0.92	2.7	3,000 /	0.30			132	174	42					
B2SM5	1.83 / 1.75 / 1.5	1.8	5.4	4,000 /	0.56	117	90	158	200	42	30	14	80	100	4.5
B3SM5	2.6 / 2.5 / 2.3	2.6	7.8	6,000	0.79			184	226	42					
C1SM5	3.8 / 3.5 / 3.1	3.9	12		2.7			178	220	42					
C2SM5	5.5 / 4.8 / 4.2	5.7	17.5	2,000 /	3.7	137	102	206	248	42	40	19	95	115	10
C3SM5	6.9 / 6.4 / 5.7	7.1	22	3,000 /	4.7			234	276	42					
C4SM5	8.3 / 7.6 / 6.8	8.5	26	4,000	6.0			262	304	42					
D1SM5	8.0 / 7.6 / 6.8	8.2	25		7.9			203	245	42					
D2SM5	11.5 / 11.0 / 9.5	11.6	36	1,500 /	11.2	169	140	233	275	42	50	24	130	165	22
D3SM5	15.0 / 14.0 / 11.9	15.3	47	2,000 /	14.4			263	305	42					
D4SM5	18.0 / 16.9 / 13.7	18.4	57	3,000	19.5			293	335	42					
E1SM5	23 / 19 / 14	23.5	37.08	1,000 /	57			266	293	34					
E2SM5	34 / 28 / 19	35.0	74.16	2,000 /	79	256.5	195	294	321	34	58	32	180	215	60
E3SM5	47 / 40 / 27	48.0	110.8	3,000	102			322	349	34					

## ENCODER SYSTEMS

Resolver resolution 12 bit/revolution

BISS Singleturn - 19 bit/revolution Multiturn -12 bit/revolution – 19 bit revolution

### Features:

right angle plug, shaft without keyway,  
PTC-Sensor, protection IP 54

### Options:

permanent magnet brake, shaft with keyway,  
protection IP65 - shaft, with forced cooling

Prepared for the operation with:

**COMBIVERT S6** **COMBIVERT F6** **COMBIVERT H6** **COMBIVERT F5**

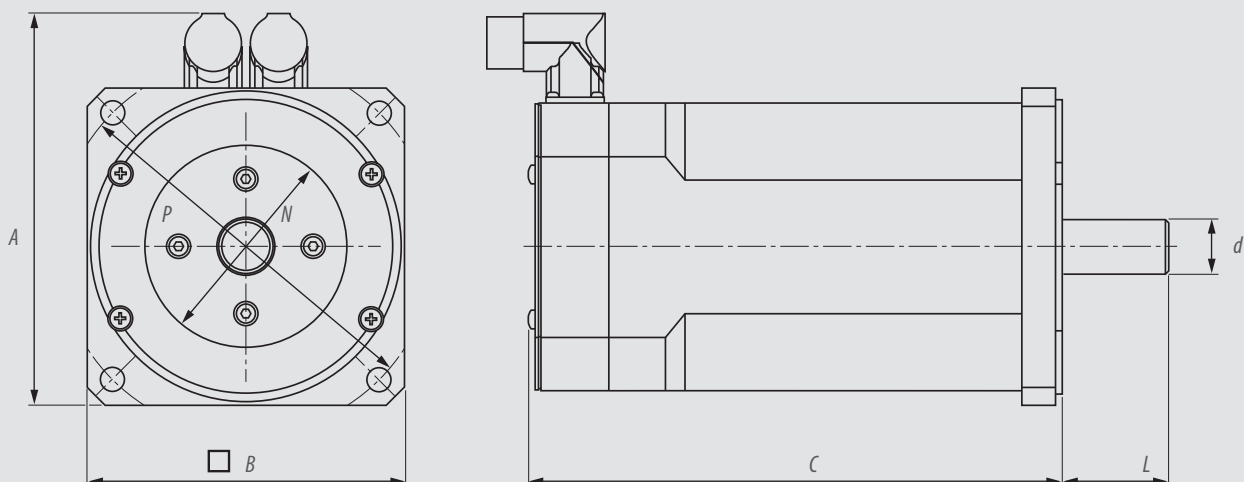

**OPTIMISED FOR MODULAR GEARBOX**

**HELICAL GEAR G**

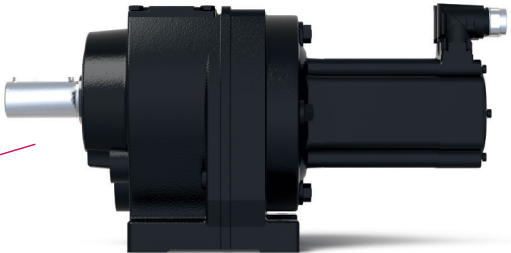
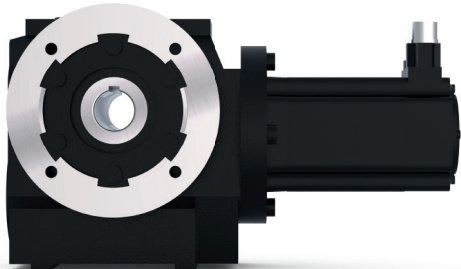

**HELICAL WORM GEAR S**

**PLANETARY GEAR (P)**



**HELICAL BEVEL GEAR K**

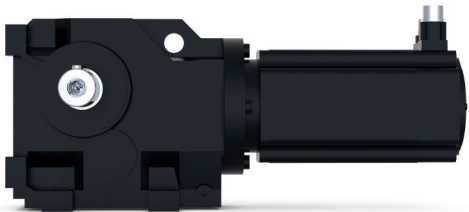

**SHAFT MOUNTED HELICAL GEAR F**

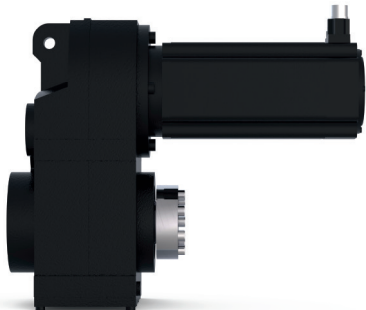

TA 1_	0.5 - 0.9
TA 2_	1.3 - 3.1
TA 3_	2.9 - 6.4
TA 4_	6.9 - 11.7
TA 5_	11.5 - 30.0
TA 6_	34.5 - 90.0

Stall torque in Nm

## TA SERIES

Servo technology in combination with an industrial gear box module gives rise to a variety of servo geared motor types:

Spur, shaft-mounted helical, helical worm, helical bevel and planetary gear.

The direct input into the gearhead reduces the work that would otherwise be required with a conventional connection coupler, increasing efficiency and service life in a particularly compact design.

As a flexible solution from the gearhead module, the servo gear motor offers high overall efficiency and excellent dynamics, as well as reduced backlash option (on request). The series TA offers properties such as lifetime lubrication, universal installation positions and robust mechanics.

## KEB DRIVE

is our perfect software tool for geared motor selections, based on a combination of continuous torque and peak current dependent on the nominal torque. It also provides technical data sheets, 2D and 3D engineering files as well as the ability to allocate a matching controller.

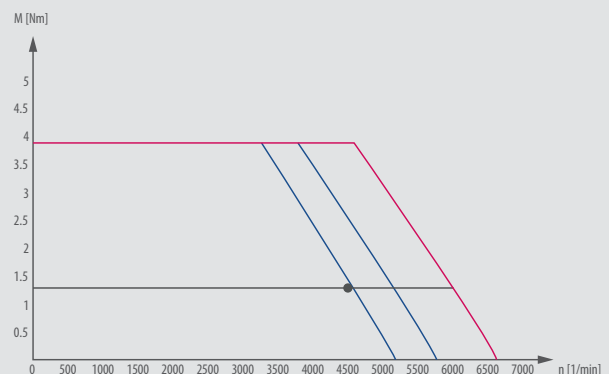
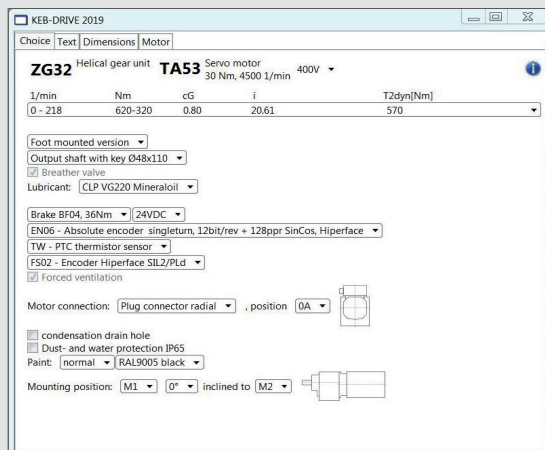

# TYPE TA

MOTOR	$T_N$ [Nm]	$T_0$ [Nm]	$T_{MAX}$ [Nm]	$n_N$ [rpm]	$J_L$ [kgcm <sup>2</sup> ]	A [mm]	B □ [mm]	C				$d_{K6}$ ∅[mm]	L [mm]	$N_{J6}$ ∅[mm]	P ∅[mm]	GEAR (available)				
								resolver	brake + resolver	absolute encoder	brake + absolute encoder					G	F	S	K	P
TA 1S	0.49 / 0.48	0.5	1.5	4,500 /	0.136	104.5	58	134	169	161	196	9	20	40	63	■	-	■	■	■
TA 1M	0.89 / 0.88	0.9	2.7	6,000	0.2			164	199	191	226					226				
TA 2S	1.29 / 1.28	1.3	3.9	4,500 / 6,000	0.391	117.5	75	153	178	180	205	11	23	60	75	■	-	■	■	■
TA 2M	2.2 / 2	2.4	7.2		0.66			193	218	220	245					245				
TA 2L	2.8	3.1	9.3		0.927			233	258	260	285					285				
TA 3S	2.6 / 2.45 / 2.25	2.9	8.7	3,000 /	1.13	132.5	90	166	216	193	243	14	30	80	100	■	■	■	■	■
TA 3M	4.2 / 3.8 / 3.4	4.8	14.4	4,500 /	1.95			216	266	243	293					293				
TA 3L	5.3 / 4.2 / 3.9	6.4	19.2	6,000	2.76			266	316	293	343					343				
TA 41	6.6 / 6.3 / 5.7	6.9	20.7	2,000 /	5.65	160	116	241	276	261	296	19	40	110	130	■	■	■	■	■
TA 42	8.6 / 8.1 / 7.1	9.2	27.6	3,000 /	8.15			276	311	296	331					331				
TA 43	10.8 / 10.1 / 8.6	11.7	35.1	4,500	10.65			311	346	331	366					366				
TA 51	10.8 / 10.2 / 9	11.5	34.5	2,000 / 3,000 / 4,500	14.9	188	145	273	308	293	328	24	50	130	165	■	■	■	■	-
TA 52	14.7 / 13.5 / 11.3	16.1	48.3		21.53			188	308	343	328					363	363			
TA 53	17.7 / 16.1 / 10.4	20	60		28.15			188	343	378	363					398	398			
TA 53F	27 / 24 / 15.5	30	60		28.15			194.5	473	528	473					528	528			
TA 61	31.5 / 30 / 26	34.5	103.5	1,500 / 2,000 / 3,000	77.71	252	188	367	407	387	427	32	58	180	215	■	■	■	■	-
TA 62	44 / 41 / 33	50	150		113.7			252	445	485	465					505	505			
TA 63	55 / 50 / 37	64	192		149.7			252	515	555	535					575	575			
TA 63F	82 / 75 / 55	90	192		149.7			257	690	730	690					730	730			

## ENCODER SYSTEMS

Resolver: resolution 12 bit/revolution

BISS: Singleturn - 19 bit/revolution / Multiturn - 12 bit/revolution – 19 bit revolution

Hiperface: Singleturn - 17 bit/revolution / Multiturn - 12 bit/revolution – 17 bit revolution

### Features:

straight plug, shaft with keyway,  
PTC-Sensor, protection IP 54

### Options:

permanent magnet brake, right angle plug,  
KTY-Sensor Protection Ip65

Prepared for the operation with

**COMBIVERT S6**   **COMBIVERT F6**   **COMBIVERT H6**   **COMBIVERT F5**

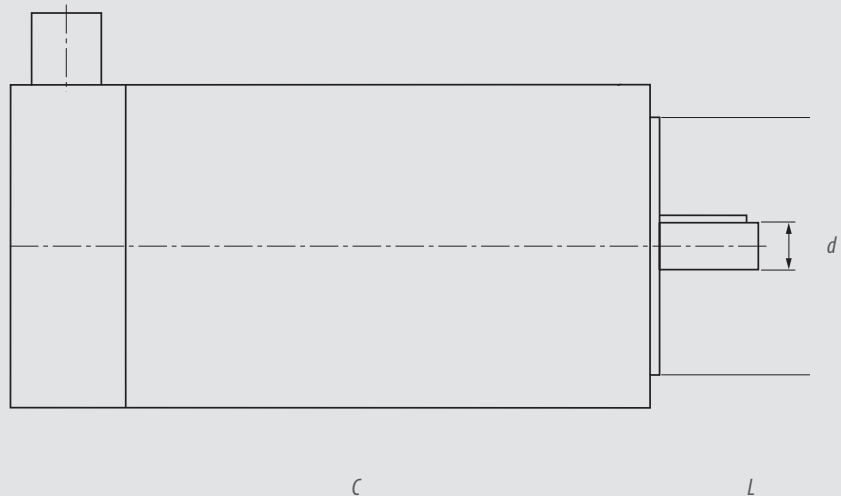

## KEB WORLDWIDE

**Austria** | KEB Automation GmbH

Ritzstraße 8 4614 Marchtrenk Austria  
 Tel: +43 7243 53586-0 Fax: +43 7243 53586-21  
 E-Mail: info@keb.at Internet: www.keb.at

**Belgium** | KEB Automation KG

Herenveld 2 9500 Geraardsbergen Belgium  
 Tel: +32 544 37860 Fax: +32 544 37898  
 E-Mail: vb.belgien@keb.de Internet: www.keb.de

**Brazil** | KEB South America – Regional Manager

Rua Dr. Omar Pacheco Souza Riberio, 70  
 BR-CEP 13569-430 Portal do Sol, São Carlos Brazil  
 Tel: +55 16 31161294 E-Mail: roberto.arias@keb.de

**France** | Société Française KEB SASU

Z.I. de la Croix St. Nicolas 14, rue Gustave Eiffel  
 94510 La Queue en Brie France  
 Tel: +33 149620101 Fax: +33 145767495  
 E-Mail: info@keb.fr Internet: www.keb.fr

**Germany** | **Headquarters**

KEB Automation KG  
 Suedstraße 38 32683 Bartrup Germany  
 Telefon +49 5263 401-0 Fax +49 5263 401-116  
 E-Mail: info@keb.de Internet: www.keb.de

**Germany** | **Geared Motors**

KEB Antriebstechnik GmbH  
 Wildbacher Straße 5 08289 Schneeberg Germany  
 Telefon +49 3772 67-0 Fax +49 3772 67-281  
 E-Mail: info@keb-drive.de Internet: www.keb-drive.de

**Italy** | KEB Italia S.r.l. Unipersonale

Via Newton, 2 20019 Settimo Milanese (Milano) Italia  
 Tel: +39 02 3353531 Fax: +39 02 33500790  
 E-Mail: info@keb.it Internet: www.keb.it

**Japan** | KEB Japan Ltd.

15 - 16, 2 - Chome, Takanawa Minato-ku  
 Tokyo 108 - 0074 Japan  
 Tel: +81 33 445-8515 Fax: +81 33 445-8215  
 E-Mail: info@keb.jp Internet: www.keb.jp

**P. R. China** | KEB Power Transmission Technology (Shanghai) Co. Ltd.

No. 435 QianPu Road Chedun Town Songjiang District  
 201611 Shanghai P. R. China  
 Tel: +86 21 37746688 Fax: +86 21 37746600  
 E-Mail: info@keb.cn Internet: www.keb.cn

**Republic of Korea** | KEB Automation KG

Room 1709, 415 Missy 2000 725 Su Seo Dong  
 Gangnam Gu 135- 757 Seoul Republic of Korea  
 Tel: +82 2 6253 6771 Fax: +82 2 6253 6770  
 E-Mail: vb.korea@keb.de Internet: www.keb.de

**Russian Federation** | KEB RUS Ltd.

Lesnaya str, house 30 Dzerzhinsky MO  
 140091 Moscow region Russian Federation  
 Tel: +7 495 6320217 Fax: +7 495 6320217  
 E-Mail: info@keb.ru Internet: www.keb.ru

**Spain** | KEB Automation KG

c / Mitjer, Nave 8 - Pol. Ind. LA MASIA  
 08798 Sant Cugat Sesgarrigues (Barcelona) Spain  
 Tel: +34 93 8970268 Fax: +34 93 8992035  
 E-Mail: vb.espana@keb.de Internet: www.keb.de

**Switzerland** | KEB Automation AG

Witzbergstraße 24 8330 Pfaeffikon/ZH Switzerland  
 Tel: +41 43 2886060 Fax: +41 43 2886088  
 E-Mail: info@keb.ch Internet: www.keb.ch

**United Kingdom** | KEB (UK) Ltd.

5 Morris Close Park Farm Industrial Estate  
 Wellingborough, Northants, NN8 6 XF United Kingdom  
 Tel: +44 1933 402220 Fax: +44 1933 400724  
 E-Mail: info@keb.co.uk Internet: www.keb.co.uk

**United States** | KEB America, Inc.

5100 Valley Industrial Blvd. South  
 Shakopee, MN 55379 United States  
 Tel: +1 952 2241400 Fax: +1 952 2241499  
 E-Mail: info@kebamerica.com Internet: www.kebamerica.com



## KEB PARTNERS WORLDWIDE

... [www.keb.de/contact/contact-worldwide](http://www.keb.de/contact/contact-worldwide)

**KEB**

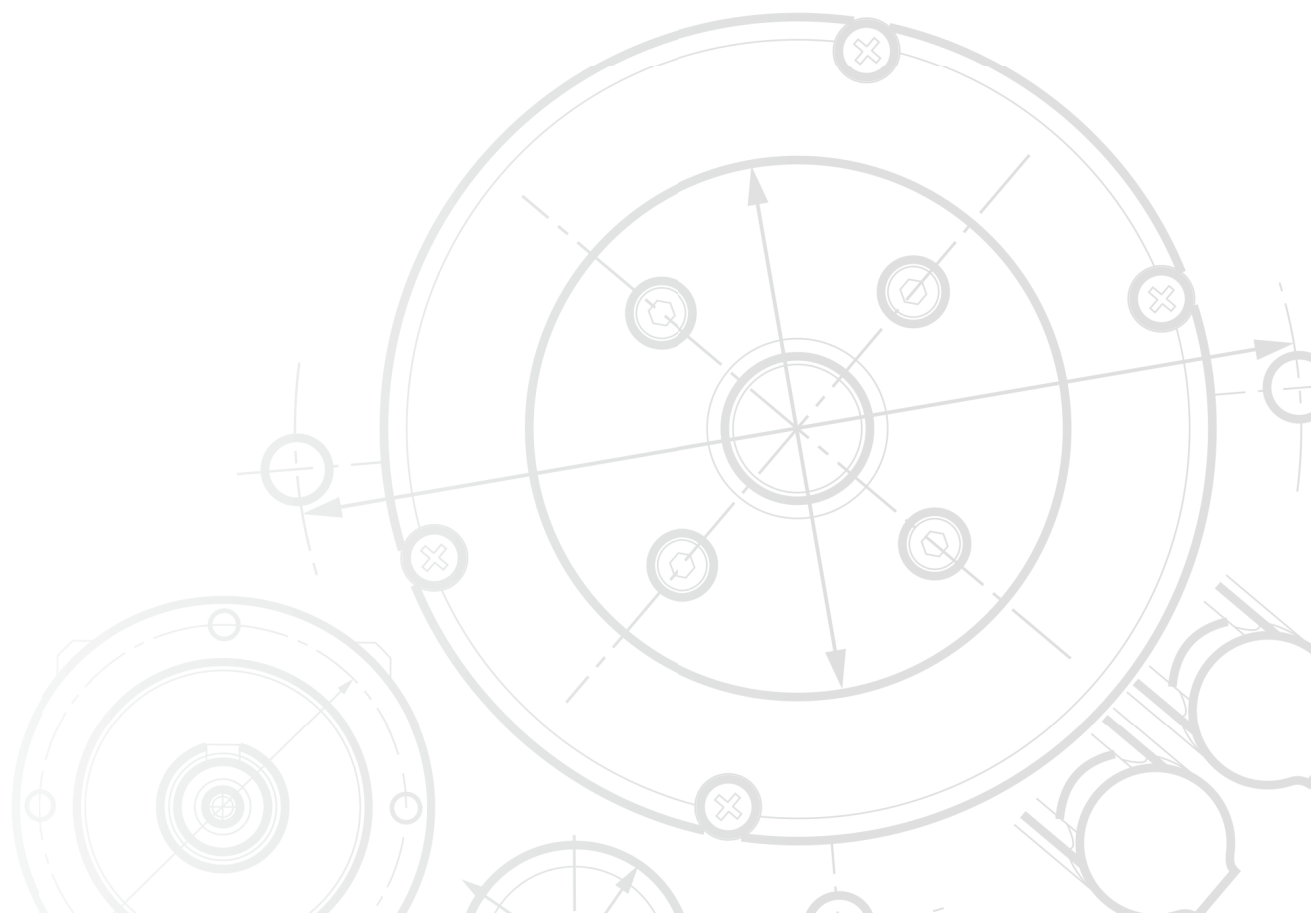

**Automation with Drive**

**[www.keb.de](http://www.keb.de)**

KEB Automation KG Suedstrasse 38 32683 Bartrup Germany Tel. +49 5263 401-0 E-Mail: [info@keb.de](mailto:info@keb.de)

© KEB 0000000-5DSM 08.2018 Subject to technical alterations!