

COMBIVERT



US Instruction Manual
Type R6-S

Power Supply and Regenerative Unit
Type 25R6S3R-R00A

Mat.No.	Rev.
00R6SUB-KR01	1A



Inhaltsverzeichnis

1.	Introduction.....	4
1.1	Preface.....	4
1.2	Product description.....	4
1.3	Validity and liability	6
1.4	Copyright.....	6
1.5	Specified application.....	6
1.5.1	Standard operation	6
1.5.2	Abnormal operation	7
1.6	Unit identification	7
2.	Safety Instructions	8
2.1	General instructions.....	8
2.2	Transport, storage and installation.....	8
2.3	Electrical connection.....	9
3.	Technical Data	13
3.1	Overload (OL) function.....	14
3.2	Operating conditions.....	15
3.3	Accessories.....	16
3.4	Options	17
3.4.1	Ferrite rings.....	18
3.3	Accessories.....	16
3.4	Options	17
3.4.1	Ferrite rings.....	18
3.5	Dimensions and weights.....	19
3.5.1	Dimensions air cooling system mounted version.....	19
3.5.2	Commutation choke / mains choke.....	20
3.5.3	Radio interference filter (side-mounted)	21
3.5.4	Synchronization unit	23
3.5.5	Fuse holder with cover.....	24
4.	Installation.....	25
4.1	EMC-compatible control cabinet installation.....	25
4.2	Installation instructions	25
4.3	Connection of the COMBIVERT R6	26
4.3.1	General description of inverter input terminals	26
4.3.2	Connection terminals of the power circuit.....	28
4.3.3	Connections of the control board.....	30
4.3.4	Connection of the synchronization unit.....	31
4.4	Connection power unit R6-S with UL.....	32
4.4.1	Power supply and regenerative operation at inverter current \leq inverter current of one COMBIVERT R6-S with UL	32
4.4.2	Power supply and regenerative operation at parallel operation with one frequency inverter.....	33
4.4.3	Power supply and regenerative operation at parallel operation with a second regenerative unit	33

4.4.4	Brief Description of the Pre-Charging Sequence.....	34
4.5	Connection of the control board version S.....	35
4.5.1	Assignment of the control terminal strip X2A.....	35
4.5.2	Assignment of the socket X2B.....	36
4.5.3	Assignment of the terminal block X2C.....	36
4.5.4	Wiring example.....	37
5.	Operation of the Unit.....	38
5.1	Operator.....	38
5.2	Keyboard.....	39
5.3	Operation with PC and system software COMBIVIS 6.....	39
5.4	Switch-on procedure.....	40
5.5	Parameter summary.....	41
5.6	Monitoring and analysis parameters.....	42
A.	Appendix A.....	53
A.1	Data Logging.....	53
A.2	Certification.....	55
A.2.1	CE Marking.....	55
A.2.2	UL Certification.....	55

List of Figures

Figure 1:	Block diagram of the COMBIVERT R6S.....	5
Figure 2:	Overload (OL) function.....	14
Figure 3:	COMBIVERT R6 with fan heat sink.....	19
Figure 4:	Mains choke.....	20
Figure 5:	Radio interference filter 24E6T60-3000 (side-mounted).....	21
Figure 6:	Radio interference filter 25E4T60-1001 (side-mounted).....	22
Figure 7:	Synchronization unit.....	23
Figure 8:	Fuse holder.....	24
Figure 9:	EMC-compatible control cabinet installation.....	25
Figure 10:	General description of the input terminals at KEB inverter.....	27
Figure 11:	Description of the input terminals of the COMBIVERT R6.....	28
Figure 12:	Connection terminals of the power circuit.....	29
Figure 13:	Connection terminals of the control board.....	30
Figure 14:	RJ45 socket for phase synchronization and temperature sensor.....	31
Figure 15:	Power supply and regenerative operation at inverter current \leq current of one COMBIVERT R6-S.....	33
Figure 16:	RJ45 socket.....	36
Figure 17:	Wiring example R6-S.....	37

Introduction



1. Introduction

1.1 Preface

First, we would like to welcome you as a customer of KEB and congratulate you on the purchase of this product. You have decided on a product of the highest technical innovation.

The enclosed documents as well as the specified hardware and software are developments of KEB. KEB has created these documents, hardware, and software and they are to the best of KEB's knowledge error free. KEB reserves the right to change specifications without prior notice. This statement is not exclusive.

The icons used throughout this document have the following significance:

	Danger
	Warning
	Caution
	Pay Attention
	Important Warning
	Information
	Help
	Tip

1.2 Product description

This instruction manual describes the power supply and recovery unit KEB COMBIVERT R6-S. The COMBIVERT R6-S has the following technical features.

As a supply unit

- converts a three-phase input voltage into DC voltage.
- supplies a single KEB frequency inverter or multiple units via DC interconnection.
- can be connected in parallel, if higher supply power is required.
- increases the stability of the DC Bus voltage in shared DC Bus applications.

As a regeneration unit

- returns the excess energy from generating operation (i.e. overhauling load) to the utility supply system.
- reduces the net energy demand.
- reduces the heat dissipation.
- is environmentally friendly.
- replaces braking resistor and braking transistor.
- is cost saving and space saving.

The COMBIVERT R6-S is generally protected against over current, ground fault and high temperature. Appropriately dimensioned DC fuses protect the DC Bus circuit against short-circuit. The following accessories are necessary for operation with the COMBIVERT R6-S:

- Commutation choke
- HF filter (for observance of European EMC standard)

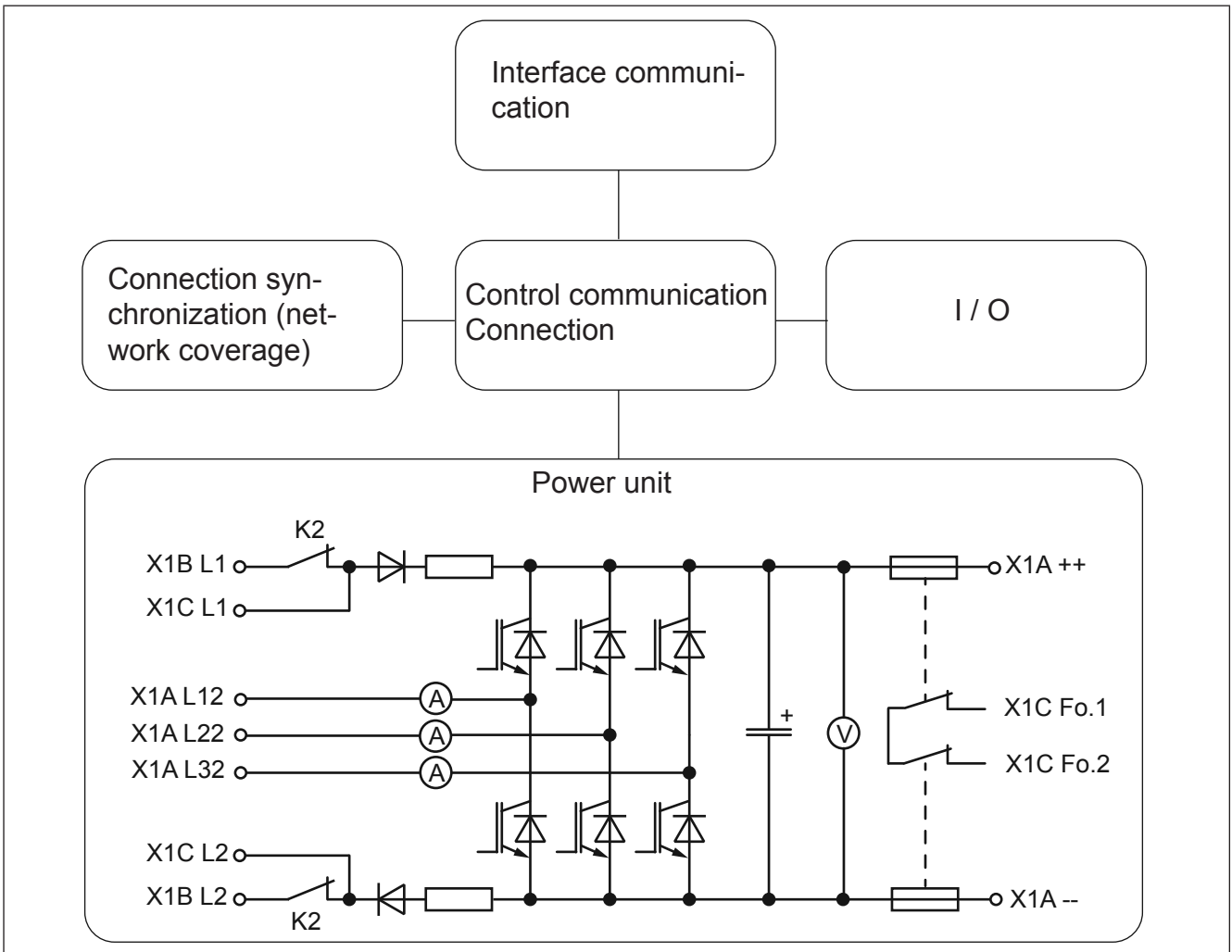

Figure 1: Block diagram of the COMBIVERT R6S

1.3 Validity and liability

Application and use of our units in the target products is outside of our control and therefore is exclusively the responsibility of the machine manufacturer.

The information contained in the technical documentation, as well as any user-specific advice in spoken and written communication are made to best of our knowledge and information about the application. However, they are considered for information only without responsibility. This also applies to any violation of industrial property rights of a third-party.

Selection of our units in view of their suitability for the intended use must be done generally by the user.

Inspections and tests can only be done by the machine manufacturer within the framework of the application. Inspections and tests must be repeated, even if only parts of hardware, software, or the unit adjustment are modified.

Unauthorized opening and improper tampering can lead to bodily injuries or liability issues and this causes loss of the warranty. Only use original spare parts and authorized accessories by the manufacturer. The use of other parts excludes liability for the consequences arising out of such use.

The suspension of liability is valid also for shutdown damages, lost profit, data loss, or other consequential damages. This is also valid if we have referred to the possibility of such damages.

Should any part of this agreement be invalid for any reason, it is to be replaced with a corresponding text, which is valid and equivalent to the intended meaning. The rest of the agreement shall remain unaffected and valid.

1.4 Copyright

The customer may use the instruction manual as well as further enclosed documents or parts from it for internal purposes. KEB has the copyrights and they remain effective also to the full extent. All rights reserved. KEB®, COMBIVERT®, KEB COMBICONTROL® and COMBIVIS® are registered trademarks of KEB Automation KG. Other wordmarks or/and logos are trademarks (TM) or registered trademarks (®) of their respective owners and are listed in the footnote on the first occurrence. When creating our documents we pay attention with the utmost care to the rights of third parties. Should we have not marked a trademark or breached a copyright, please inform us in order to rectify the issue.

1.5 Specified application

The COMBIVERT R6-S serves exclusively for the supply of frequency inverters with DC input and/or regeneration of excess energy into the supply system. The operation of other electrical loads is prohibited and can lead to malfunctions or destruction of the unit.

The used semiconductors and components of KEB are developed and dimensioned for use in industrial products. If the product is used in machines, which work under exceptional conditions or if essential functions, life-supporting measures or an extraordinary safety step must be fulfilled, the necessary reliability and security must be ensured by the machine manufacturer. The operation of our products outside the indicated limit values of the technical data leads to the loss of any liability claims.

All control card outputs of the R6 are „one-channel, no diagnostic coverage and therefore not safe“ according to ISO 13849. If required, additional protective measures must be met by the user.

1.5.1 Standard operation

If the DC Bus voltage increases to a value above the peak value of the line voltage (negative power), regeneration of the current to the line occurs automatically. The line voltage is measured by the R6 unit. Regeneration occurs in a square-wave format, whereby the current flow period corresponds to the line frequency and the normal conduction times of a standard 6 pulse bridge rectifier circuit. Regeneration stops if the DC bus voltage decreases below the line supply peak voltage (positive power).

1.5.2 Abnormal operation

When exceeding the permissible limit values for voltage, current or temperature the current flow between DC link and mains is blocked during regeneration. An appropriate error message is also displayed during supply. The unit must be disconnected from the supply system or the load must be switched off in case of overcurrent or overload. This can be done by opening the control release of the frequency inverter.

At factory setting the modulation is switched off in case of a net phase failure and error message E.nEt is displayed.

Special adjustments from KEB are necessary if the modulation and/or the standard operation should start again within a defined time in case of return of power supply.

1.6 Unit identification

25	R6	S	3	R-R	0	0	A		
Type								A: Standard	
								D. ext. fan power supply	
								H: Water cooling	
Design								0: Standard	
reserved								0: Standard	1: modified standard
Voltage								R: 3-ph.; 480 V; AC	
Housing								R	
Options								3: Precharging, DC fuses	
Control								S: 2B.R6	
Series								R6	
Unit size								25	

2. Safety Instructions

2. Safety Instructions

2.1 General instructions

 <p>CAUTION - Risk of Electrical Shock</p>	<p>The COMBIVERT R6 power supply and recovery unit contains dangerous voltages which can cause death or serious injury.</p> <p>The COMBIVERT R6 can be adjusted such that energy is returned to the line supply system even in case of power failure during generator operation. Therefore, dangerous high voltage can exist in the unit even after disconnection from the line supply system.</p> <p>Before working with the unit always verify the voltage has dropped to a safe value by measuring both the DC bus voltage and the AC line voltage at the R6 unit.</p> <p>Care should be taken to ensure correct and safe operation and to minimize risk to personnel and equipment.</p>
--	--

 <p>Only quali- fied electro- personnel</p>	<p>All work from the transport, to installation and start-up as well as maintenance may only be done by qualified personnel (IEC 364 and/or CENELEC HD 384 and IEC-Report 664 and note national safety regulations). According to this manual, qualified personnel means those who are able to recognize and judge the possible dangers based on their technical training and experience as well as those with knowledge of the relevant standards and who are familiar with the field of power transmission or conversion.</p>
---	---

 <p>Observe standards</p>	<p>The COMBIVERT R6 must not be started until it is determined that the installation complies with 89/392/EEC (machine directive) as well as the EMC-directive (89/336/EEC)(note EN60204), the US - NEC, and the OSHA machine safety code.</p> <p>The COMBIVERT R6 meets the requirements of the Low-Voltage Directive 73/231/EEC. The harmonized standard of the series EN 61800-5-1 (VDE 0160) is used.</p> <p>This is a product of limited interference susceptibility in accordance with IEC 61800-3. This product may cause radio interference in residential areas. In this case the installer/operator may need to take corresponding measures.</p>
---	--







2.2 Transport, storage and installation

The storage and transport of the COMBIVERT must be done in the original packaging. It is to be protected against humidity and excessive cooling and thermal effects. Long-distance transportation must be carried out in the original packaging. It is to be secured against physical impact and shock during transport. Verify the packaging for signs of mishandling before removal from the packaging. Contact the shipper in case of damage. After removing the final packing, the COMBIVERT R6 must be mounted on a stable mounting base.



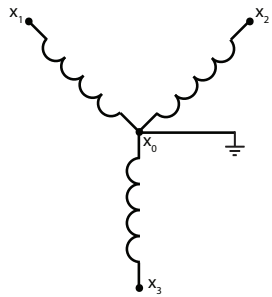

 <p>Protect Against Accidental Contact</p>	<p>The COMBIVERT R6 must be protected against abnormal operation. Components and covers must not be bent or moved as this may affect insulation distances. The units contain electrostatically endangered components which can be destroyed by inappropriate handling. For that reason, the handling of electronic components and circuit boards is to be avoided. The equipment must not be switched on if it is damaged as it may no longer comply with mandatory standards.</p> <p>Make sure during installation there is at least the minimum clearance and enough cooling. Climate conditions must be observed in accordance with this instruction manual.</p>
--	---



 <p>Hot surface</p>	<p>Heatsinks can reach high temperatures, which can cause burns when touched. A warning notice "hot surface" must be mounted on the machine control panel if direct physical contact with the heatsink cannot be avoided.</p>
---	---

2.3 Electrical connection

 <p>Note Capacitor Discharge Time</p>	<p>Before any installation and connection work, the system must be switched off and secured. After switch off, the intermediate circuit capacitors are still charged with high voltage for a short period of time. The unit can be worked on after it has been switched off for 5 minutes.</p>
 <p>Secure Isolation</p>	<p>The terminals of the control terminal strip are securely isolated in accordance with EN 61800-5-1. With existing or newly wired circuits the person installing the units or machines must ensure the EN requirements are met. When used together with frequency inverters that are not isolated from the supply circuit, all control lines must be secured by other protective measures (e.g. double insulation or shielded, earthed and insulated).</p>
 <p>Voltage With Respect to Ground</p>	<p>Connection of the COMBIVERT R6 is only permissible on symmetrical networks with a maximum line voltage (L1, L2, L3) with respect to ground (N/GND) of 305V. An isolating transformer must be used for networks which exceed this value! The unit may be damaged if this is not observed.</p>
 <p>Grounded Delta Supply</p>	<p>Connection of the R6 series inverters to voltage systems configured as a corner grounded delta, center tap grounded delta, open delta, or ungrounded delta may defeat the internal noise suppression of the inverter. Increased high frequency disturbance in the controller and on the line may be experienced. A balanced, neutral grounded wye connection is required. The three phase voltage imbalance must be less than 2% phase-to-phase. Greater imbalance can lead to damage of the inverter's power circuit. It is acceptable to use a transformer with a WYE connection on the secondary.</p> <p>Example of a center grounded wye transformer:</p> 
 <p>Stationary connection</p>	<p>The COMBIVERT R6 is designed for fixed connection only as high frequency ground leakage currents of > 3.5 mA may occur especially when using EMI filters. It is therefore necessary to use a ground conductor with a section of at least a #4 AWG (16mm²) copper conductor or a second ground conductor in compliance with EN61800-5-1. Ground point-to-point with the shortest connection possible to the main ground point in the system (avoid ground loops).</p>
 <p>Insulation Measurement</p>	<p>When doing a high voltage insulation measurement in accordance with VDE 0100 / Part 620, the power semiconductor of the unit and existing radio interference filters must be disconnected because of the danger of destruction. This is permissible in compliance with the standard, since all units are given a high voltage test during the quality testing at KEB in accordance with EN 50178.</p>

2. Safety Instructions

 Different Ground Potentials	<p>When using components without isolated inputs / outputs, it is necessary that equal potential bonding exist between the components to be connected (e.g. through the equalizer). Disregard can cause destruction of the components by the equalizing currents.</p>
 Fuse Sizing with Isolation Transformer	<p>When the R6 unit is supplied through an isolation transformer, the maximum allowable fuse size is dictated by the size of the transformer as defined in the National Electric Code (NFPA-70 or CSA 22.1). As per Article 450-3(B) of NFPA-70 (similar statements can be found in CSA 22.1), the max fuse size is defined in table 450.3(B) with a rating not greater than 125% of the rated secondary current. In the case of multiple secondaries, it is the rated value of the winding which the unit is supplied from. In this case it is to be assumed that the end customer will fuse the transformer primary side with fuses exceeding 125% of transformer rated input current. The value of this secondary fuse may be less than the max fuse value listed in the technical data section 3.1 of this manual. The fusing of the transformer supersedes the fuse rating of the unit because the value required for the transformer is lower than the max value with which the unit was tested.</p>
 Prevent disturbances	<p>Trouble-free and safe operation of the COMBIVERT R6 is only guaranteed when the connection instructions below are strictly followed. Incorrect operation or damage may result from incorrect installation.</p> <ul style="list-style-type: none"> • Pay attention to the line supply voltage. • Supply connection must be a symmetrical, center-grounded wye. • Install power cables and control cables separately (>6.0 inches (15 cm) separation). • Use shielded / twisted control lines. Connect the shield at one end to the COMBIVERT R6-S GND terminal! • Only use suitable circuit elements to control the logic and analog inputs, whose contacts are rated for extra-low voltages. • The heatsink of the COMBIVERT R6 must be well grounded. Shields of large power cables must be directly and securely attached to both the inverter GND terminal and the motor ground terminal. Remove paint finish where necessary. • Ground the cabinet or the system with the shortest connection to the main ground point (avoid ground loops) • Use exclusively the commutation choke or harmonic filter specified by KEB. • The average value of the supplied DC current may not exceed the maximum DC current. • If several frequency inverters are connected to the COMBIVERT R6, the maximum permissible DC bus capacities of all connected frequency inverters must be considered during supply operation (see technical data). • A ferrite ring must be installed over both + and - DC bus connections to the COMBIVERT R6 unit to limit common mode noise on the DC bus.
 Automatic Restart	<p>The COMBIVERT R6 can be adjusted in such a way that the unit will restart automatically after an error (e.g. single-phase brown out or loss). System design must take this into account. If appropriate, additional monitoring or protective features should be added where necessary.</p>
 Not Short-Circuit Proof (Supply)	<p>The COMBIVERT R6 is not short-circuit proof as a power supply input! If the I2t - protection is adapted with a class gR fuse, a conditional protection at supply input is possible. If necessary, the short-circuit protection at DC output is ensured by internal class aR fuse.</p>

 <p>Conditionally Short-Circuit Proof</p>	<p>The COMBIVERT R6 is conditionally short-circuit proof (EN61800-5-1 / VDE 0160). After resetting the internal protection devices, the function as directed is guaranteed.</p> <p>Exception:</p> <ul style="list-style-type: none"> • A ground fault or short-circuit frequently occurring at the output, can lead to damage to the unit.
 <p>Cyclic Turn On and Turn Off</p>	<p>With applications requiring the COMBIVERT R6 to be switched on and off cyclically, maintain an off-time of at least 5 min. If you require shorter cycle times please contact KEB. Switching off during the initialization phase can cause undetermined conditions.</p>
 <p>GFI (Ground Fault Interrupt Circuit-Breaker)</p>	<p>If personnel protection of the system against ground fault is required, the COMBIVERT R6-S must be protected according to EN61800-5-1:</p> <ul style="list-style-type: none"> • 3-phase inverters (with B6 bridge-connected rectifier) by RCMA's with separation (use privileged) or RCD's type B (all-current sensitive GFI's) <p>The tripping current should be 300mA or more, in order to avoid a premature triggering by leakage currents (about 200mA. Dependent on the load, the length of the motor cable and the use of a radio interference filter, substantially higher leakage current can occur). The connection instructions from the manufacturer and the valid local requirements must be observed.</p> <p>Dependent on the available supply type (TN, IT, TT) further protective measures are necessary in accordance with VDE Part 410 4(Part4; Chapter 41).</p> <p>For example, with TN-mains this protection is made with over current protective devices, with IT-mains it is insulation monitoring with a pulse-code measuring method. A protective separation can be used with all mains forms as long as the required power and cable lengths permit this.</p> <p>The person setting up the unit must present proof of compatibility before installing the converter!</p>

2.4 EMC instructions

The COMBIVERT R6-S represents electrical equipment designed for use in industrial and commercial installations. In accordance with the EMC directive 89/336/EEC, it is not mandatory to mark these devices as they represent components to be further handled by the respective machine and system manufacturer and are not operable independently according to the EMC directive. The person installing / operating the machine / system is obliged to prove the protective measures demanded by the EMC directive are complied with. The prescribed ratings can usually be complied with when using the radio interference voltage filters as specified by KEB, and when observing the following measures and installation guidelines.

2.5 EMC conforming installation

The COMBIVERT R6 is designed to be used in a second environment as defined in EN 61800-3 (unit with its own supply transformer). Take additional measures when using it in the first environment (residential and commercial area connected to public low-voltage line)!

- Install the control cabinet or system in an appropriate and correct manner (see chapter “control cabinet installation”)
- To avoid coupled noise, separate during installation high voltage supply lines, motor lines, control and data lines (low-voltage level < 48V) and leave a space of at least 6.0 inches, 15 cm between them.
- In order to maintain low-resistance high frequency connections, grounding and shielding, as well as other metallic connections (e.g. mounting plate, installed units), must be made with bare metal to metal contact with the mounting plate, over as large a surface area as possible. Use ground conductors with a section as large as possible, minimum #4 AWG (16mm²) or use thick ground straps.
- Only use shielded cable with copper or tin-plated braid, since steel braid is not suitable for high frequency ranges. The shield must always be connected to the ground bare on the unit or fastened with clamps to the bare metal of the sub mounting plate. Do not connect the shield using the drain wires alone, this reduces the effectiveness of the shield by 70%!
- If external interference suppression filters are used, then these must be installed as close as possible <12 inches (30 cm) to the interference source and must be in metal to metal contact with the sub mounting plate, over as large a surface area as possible.
- Always equip inductive control elements, (contactors, relays etc.), with suppressors such as varistors, RC-elements or diodes.

All connections must be kept as short as possible and as close as possible to the ground plane. Free floating cables act as active and passive antenna.

- Keep connection cables straight (do not loop). Tie all spare unassigned wires at one end to the ground.
- The twisted pair cables should be used when the conductors are not shielded in order to dampen common-mode noise.
- The cable for phase synchronization between the commutation choke and COMBIVERT R6-S may not exceed a line length of 39 inches (1 m) .
- Further information can be found on our website at www.kebamerica.com.

3. Technical Data

Unit size			25
Housing size			R
Phases			3
permitted mains forms	5)		TN, TT
Rated voltage		[V]	400
Mains voltage range		[V]	305...528
Mains frequency		[Hz]	50 / 60 ±2
DC voltage range		[V _{DC}]	420...747
Regenerative operation			
Output rated power	Sn	[kVA]	153
Rated active power		[kW]	140
Max. power output		[kVA]	230
Max. active power		[kW]	210
Regenerative rated current	*)	[A]	221 (184)
Regenerative DC current	1)	[A _{DC}]	270
Overload current (E.OL) 60s	2)	[A]	331
Max. regenerative DC current 60s		[A _{DC}]	405
Power supply operation			
Input rated power	Sn	[kVA]	153
Rated active power		[kW]	140
Max. input power		[kVA]	230
Max. active power		[kW]	210
Rated supply current	*), 3)	[A]	221 (184)
DC supply current	1)	[A _{DC}]	270
Overload current (E.OL) 60s		[A]	331
Max. DC supply current 60s		[A _{DC}]	405
Overload disconnection (E.OL)		[%]	160
Overvoltage switch-off (E.OP)		[V _{DC}]	840
Output rated voltage		[V _{DC}]	540
Max. permissible DC link capacity	4)	[mF]	50 (400 V class) 35 (480 V class)
Max. permissible total load current at precharging (I _{LSF})		[A _{AC}]	≤4
∫t Integral of the limiting load of the semiconductor		[A ² s]	39000
Max. permissible mains fuse type gR / aR		[A]	315
Permissible mains fuse (no delta power system)			Siemens 3NE8731 / Eaton Bussmann 170M1372 or 170M1422
Permissible mains fuse (no delta power system) for UL			Ferraz Shawmut HSJ300, rated 300A / 600Vac
Max. permissible DC fuse Bussmann Type aR			see options
Short-circuit factor at the connection point (S _{kn} /S _n) or (S _{scp} /S _n)			15 < S _{kn} "/S _n < 350
Power loss at nominal operating		[W]	1300
Max. heat sink temperature		[°C]	88

*) The values in brackets must be observed when UL approval is required!

1) Lay two connection cables parallel at supply and regenerative current > 230 A DC.







2) The overload current is specified for 1 minute. The overload cycle is 300 seconds. This corresponds to duty class 2 EN2-60146-1.

3) The current data are based on a fundamental frequency component of g=0.95. The fundamental frequency component or the effective value of the input current is dependent on load and line supply conditions. At uncontrolled B6 converters the phase angle cosφ1 can be set to one, so the value of the fundamental frequency components is equal to the value of the power factor.

4) Please contact KEB for higher values.

3. Technical Data

5) Connection to IT and delta power systems after consultation KEB.

	Voltage stabilization must be activated at the inverter if a harmonic filter is used. If a harmonic filter is used, voltage stabilization must be activated for the inverter which is connected to the DC circuit.
	Exceeding of the max. rechargeable DC link capacity can lead to a defect.
	A load removal in the DC link circle may be done only after the message "ready".
	If the control release is set when switching off the mains, this can lead to an overcurrent error and the lifetime of the module can be reduced.
	The load must be disconnected in case of overcurrent or overload.
	The device must be disconnected from the mains supply if a mains fuse has triggered.

3.1 Overload (OL) function

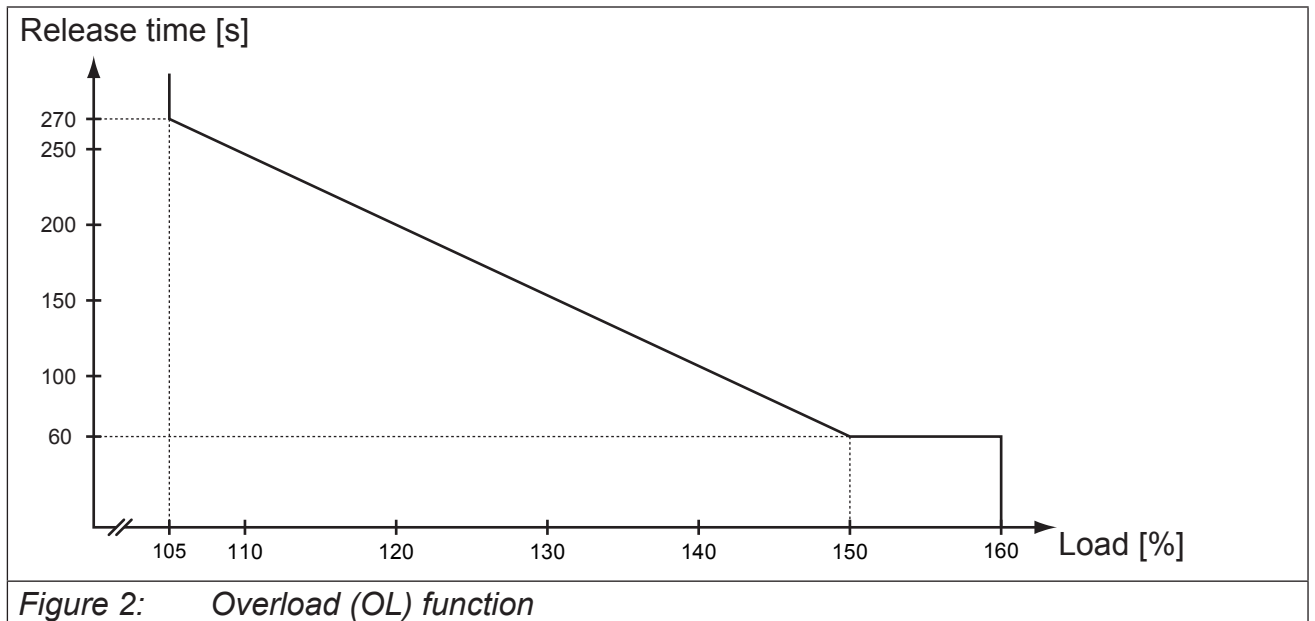

3.2 Operating conditions

		Standard	Standard/ class	Instructions
Definition according to		EN 61800-2		Inverter product standard: rated specifications
		EN 61800-5-1		Inverter product standard: general safety
Site altitude				max. 2000m above sea level (with site altitudes over 1000m a derating of 1% per 100m must be taken into consideration)
Ambient conditions during operation				
Climate	Temperature	EN 60721-3-3	3K3	extended to -10...45 °C (with temperature over 45°C to max. 55°C a derating of 5% per 1K must be taken into consideration)
	Humidity		3K3	5...85% (without condensation)
Mechanical	Vibration		3M1	max. amplitude of a vibration 1 mm (5...13Hz) max. acceleration amplitude 7 m/s ² (13...200Hz)
Contamination	Gas		3C2	
	Solids	3S2		
Ambient conditions during transport				
Climate	Temperature	EN 60721-3-2	2K3	
	Humidity		2K3	(without condensation)
Mechanical	Vibration		2M1	max. vibration amplitude 3.5 mm (2...9Hz) max. acceleration amplitude 15 m/s ² (9...200 Hz)
	Surge		2M1	max. 100 m/s ² ; 11 ms
Contamination	Gas	2C2		
	Solids	2S2		
Ambient conditions for the storage				
Climate	Temperature	EN 60721-3-1	1K4	
	Humidity		1K3	(without condensation)
Mechanical	Vibration		1M1	max. amplitude of a vibration 1 mm (5...13Hz) max. acceleration amplitude 7 m/s ² (13...200 Hz)
	Surge		1M1	max. 100 m/s ² ; 11 ms
Contamination	Gas	1C2		
	Solids	1S2		
Type of protection		EN 60529	IP20	
Environment		IEC 664-1		Pollution degree 2
Definition according to		EN 61800-3		Inverter product standard: EMC
EMC emitted interference				
Cable-based interferences		EN 55011	C2	with EMC filter & ferrite up to 100m line length
Radiated interferences		EN 55011	C2	with EMC filter and ferrite
Interference immunity				
Electro-static discharge		EN 61000-4-2	8 kV	AD (air discharge) and CD (contact discharge)
Burst - control lines + bus		EN 61000-4-4	2 kV	
Burst - mains supply		EN 61000-4-4	4 kV	
Surge - mains supply		EN 61000-4-5	1 / 2 kV	Phase-phase / phase-ground
Immunity to conducted disturbances, induced by radio-frequency fields		EN 61000-4-6	10 V	0.15-80 MHz
Electromagnetic fields		EN 61000-4-3	10 V/m	
Voltage variation / voltage drop		EN 61000-2-1		+10%, -15%; 90%
Voltage unsymmetries / frequency changes		EN 61000-2-4		3%; 2%

3. Technical Data

3.3 Accessories

Unit size	25
Rated voltage	400 V
Commutation choke	25Z1B04-1000
Synchronization unit	00R6940-2407 Control cabinet installation; max. distance to the power supply and regenerative unit 1m

3.4 Options

Unit size	25
HF radio interference filter (EMC)	For an ED of max. 82 % -> 24E6T60-3000 For an ED of 100 % -> 25E4T60-1001 in accordance with EN 61800-3 C2 (only with ferrite rings) C1 (after consultation with KEB)
DC fuses	690V/400A Mat.No. 009025H-4651
Micro switch for fuse 009025H-4651	0090278-0001
Fuse holder for NH00 and NH000 fuses	0090574-0001
Harmonic filter (no UL certification)	25Z1C04-1000 ²⁾ Please contact KEB for data to the THD value at regenerative operation in accordance with EN 61800-2-12.
Harmonic filter (with UL certification)	Compliance with the IEEE519 requirements at a 480V / 60Hz mains is possible with the following harmonic filter: 22Z1C05-1001, 23Z1C05-1001, 24Z1C05-1001, 25Z1C05-1001
Operators	Digital operator, interface operator
Bus operators	CANopen®, ProfiBus®, INTERBUS®, EtherCAT®, Ethernet®, Sercos, ModBus, PROFINET® ³⁾ , LCD, Devicenet, HSP5
¹⁾	The ON time ED refers to the regenerative unit R6-S
²⁾	Depending on the load, the following harmonic filters are also possible with the technical data given therein: 20Z1C04-1000, 21Z1C04-1000, 22Z1C04-1000, 23Z1C04-1000, 24Z1C04-1000
³⁾	ProfiNet from operator firmware V3.4 of 30.01.2015

CANopen® is a registered trademark of the CAN in AUTOMATION - International Users and Manufacturers Group e.V

INTERBUS® is a registered trademark of Phoenix Contact GmbH & Co. KG.

EtherCAT® is a registered trademark and patented technology licensed by Beckhoff Automation GmbH, Germany

Industrial Ethernet® is a registered trademark of Siemens AG

PROFIBUS® is a registered trademark of Siemens AG

PROFINET® is a registered trademark of Siemens AG

3. Technical Data

3.4.1 Ferrite rings

Ferrite rings are used for the reduction of the cable-based and radiated interferences. For high damping, the ferrite rings are attached as close as possible to the interference source, i.e. at the DC bus connections and at the motor output terminals of the frequency inverter. The conductors must be passed through the ferrite core for use as a current-compensated choke. PE must be passed outside of the ferrite ring. Further information can be taken from the provided documentation. Which ferrite ring shall be used is dependent on the used cable cross-section.

Part number	Nominal size in mm	Inside diameter in mm
0090396-2621	R 42/26/18	24.9
0090390-5241	R 56/32/18	29.5
0090395-3820	R 63/38/25	36.0
0090395-5222	R 87/54/30	54.5
0090395-5520	R 102/66/15	64.5

3.5 Dimensions and weights

3.5.1 Dimensions air cooling system mounted version

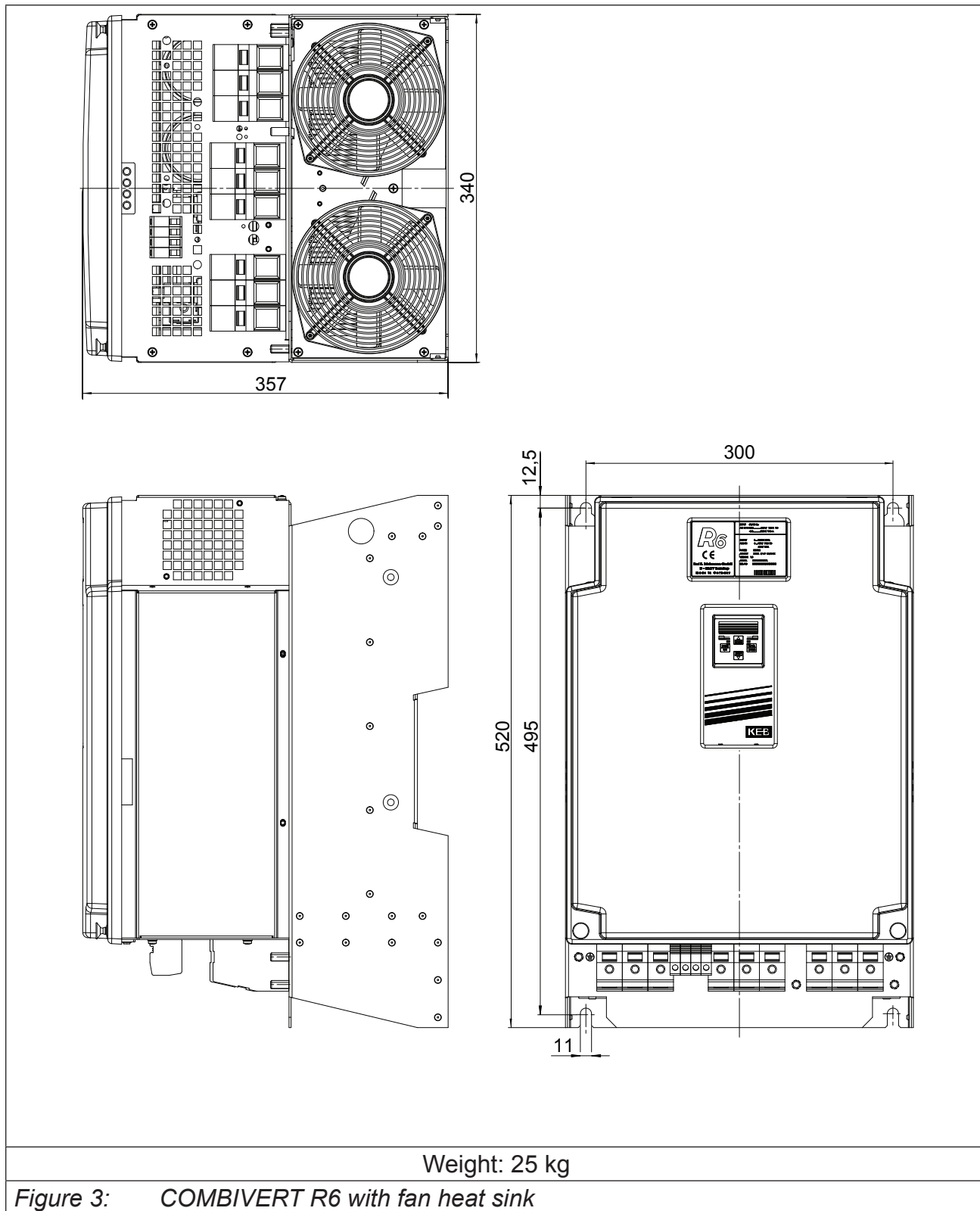

3.5.2 Commutation choke / mains choke

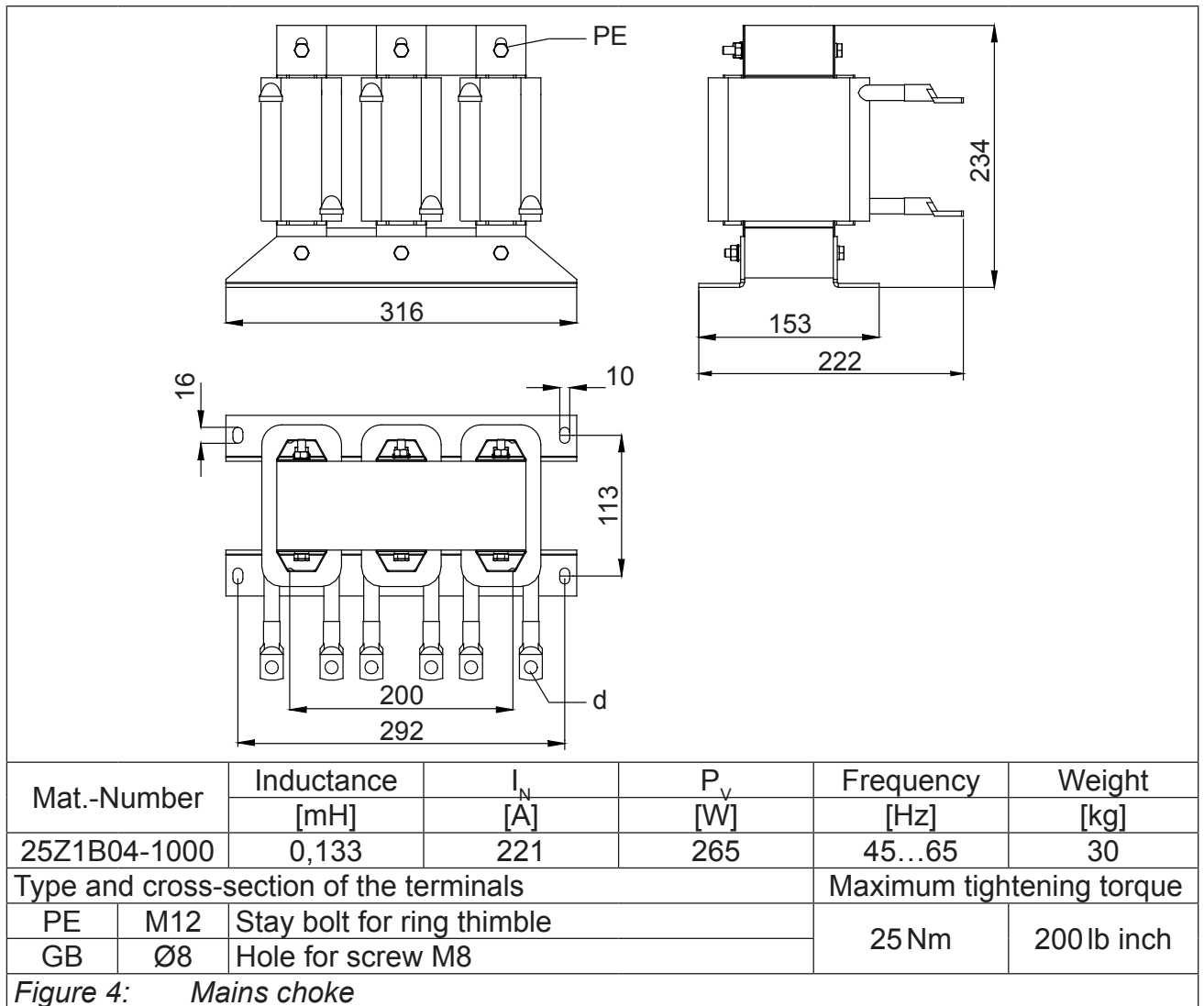

3.5.3 Radio interference filter (side-mounted)

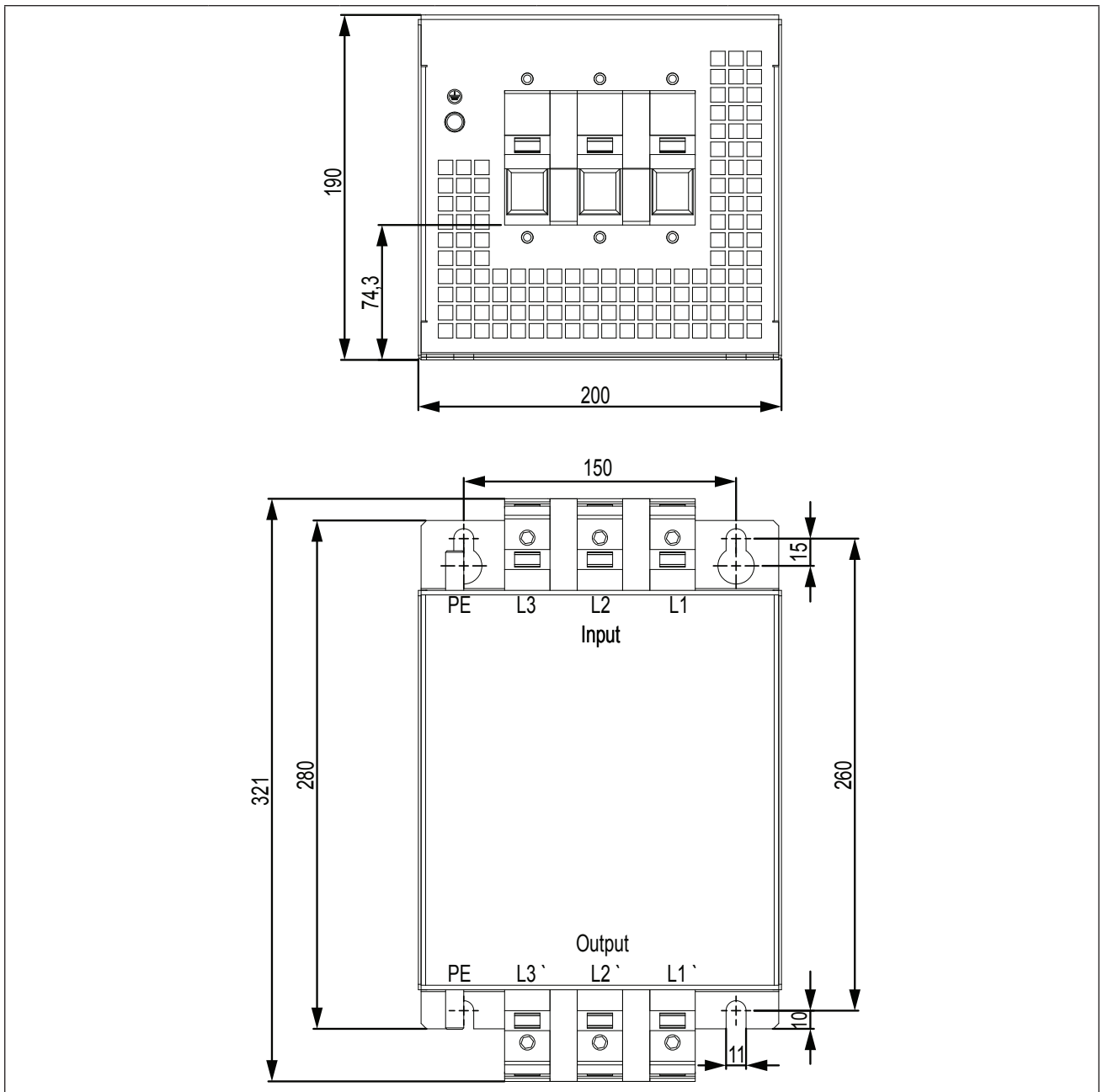

Mat.-Number	U_N	I_N	P_V	f_N	Weight
	[V]	[A]	[W]	[Hz]	[kg]
24E6T60-3000	3x480	200	100	50 / 60 ± 2	9.2
Type and cross-section of the terminals/-cable				Maximum tightening torque	
PE	M10 stay bolt for ring thimble			35 Nm / 310 lb inch	
Terminals L1, L2, L3, L1', L2', L3'	35...95 mm ² / AWG 4...AWG 4/0			15 Nm / 133 lb inch	

Figure 5: Radio interference filter 24E6T60-3000 (side-mounted)

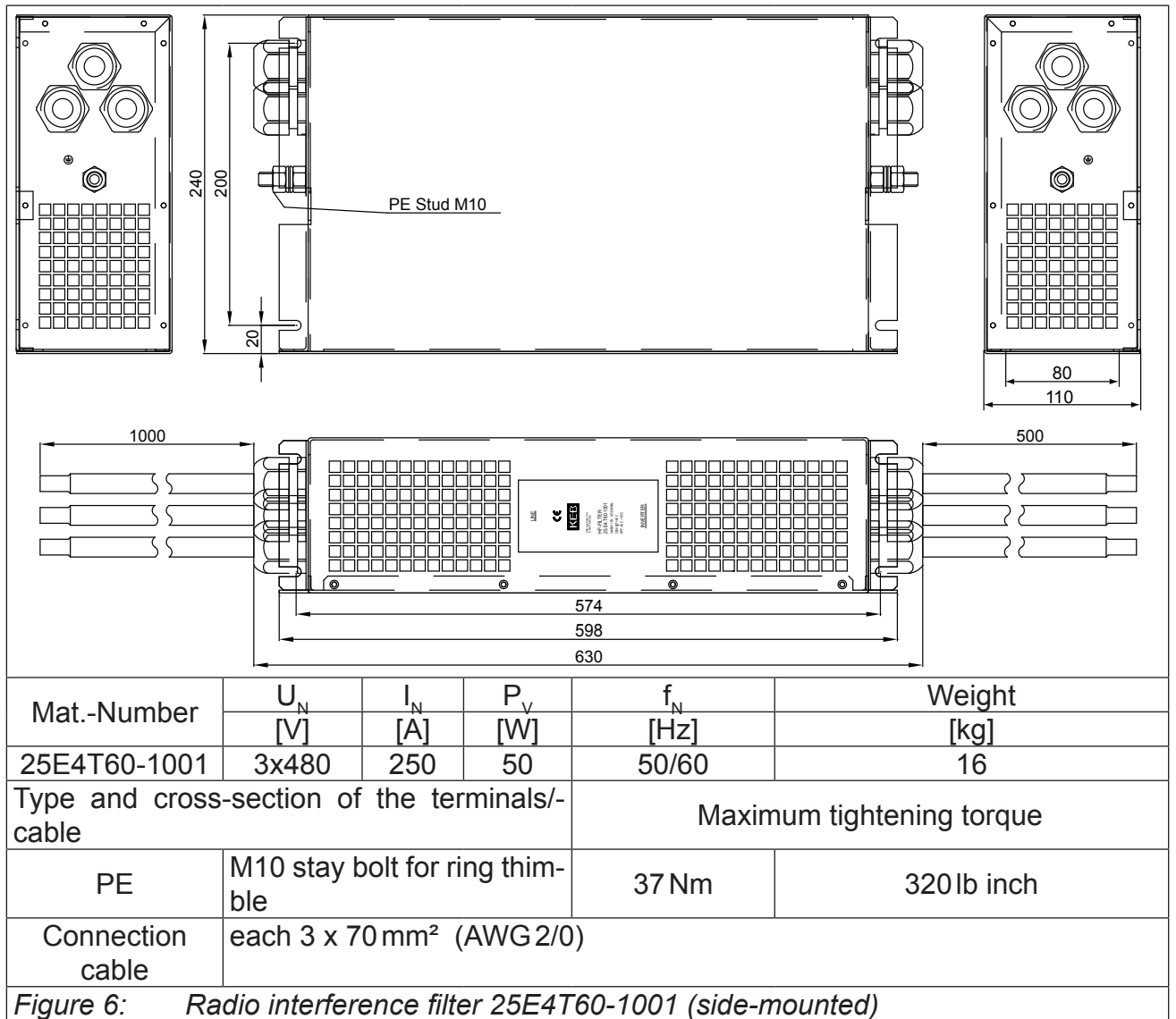
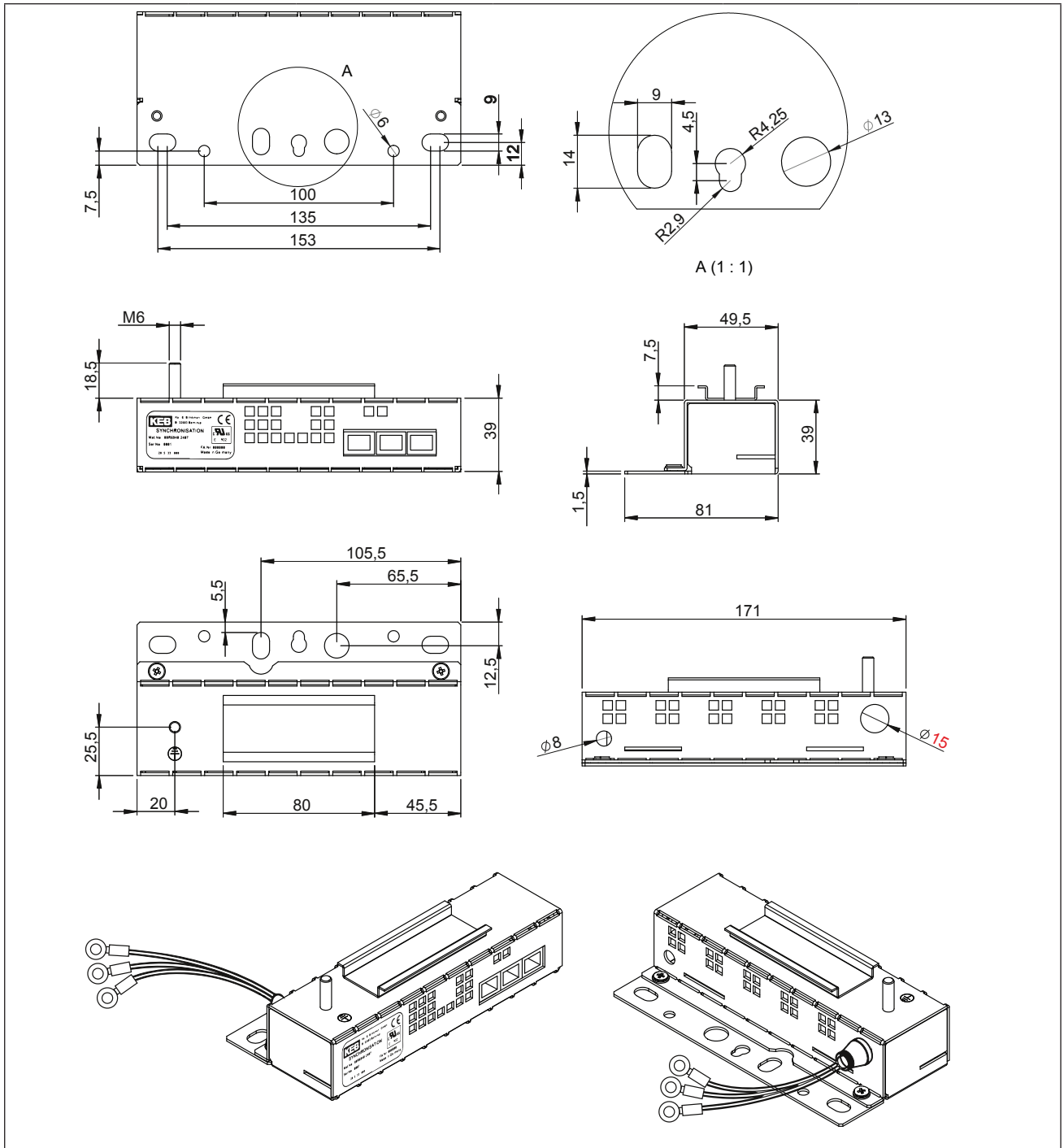

Figure 6: Radio interference filter 25E4T60-1001 (side-mounted)

3.5.4 Synchronization unit



Part number	Weight	Terminal	connection	Line length	Max. tightening torque
00R6940-2407	0.65 kg	PE	M6 stay bolt for ring thimble	-	4.5 Nm / 40 lb inch
		L1.1, L2.1, L3.1	M4 ring cable lug (AWG 16)	240 mm	-

Figure 7: Synchronization unit

3.5.5 Fuse holder with cover

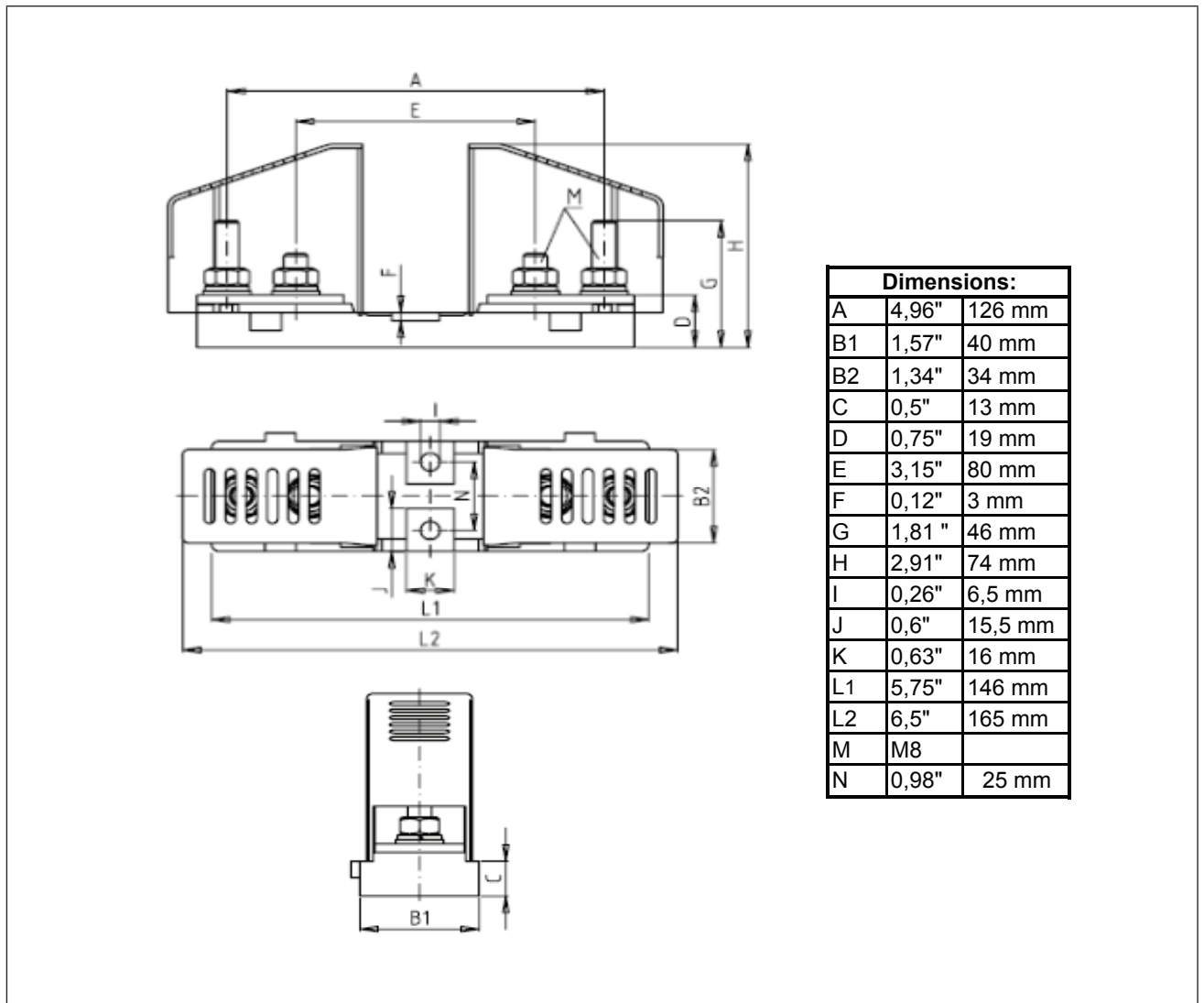

Part number: 0090574-0001

Figure 8: Fuse holder

4. Installation

4.1 EMC-compatible control cabinet installation

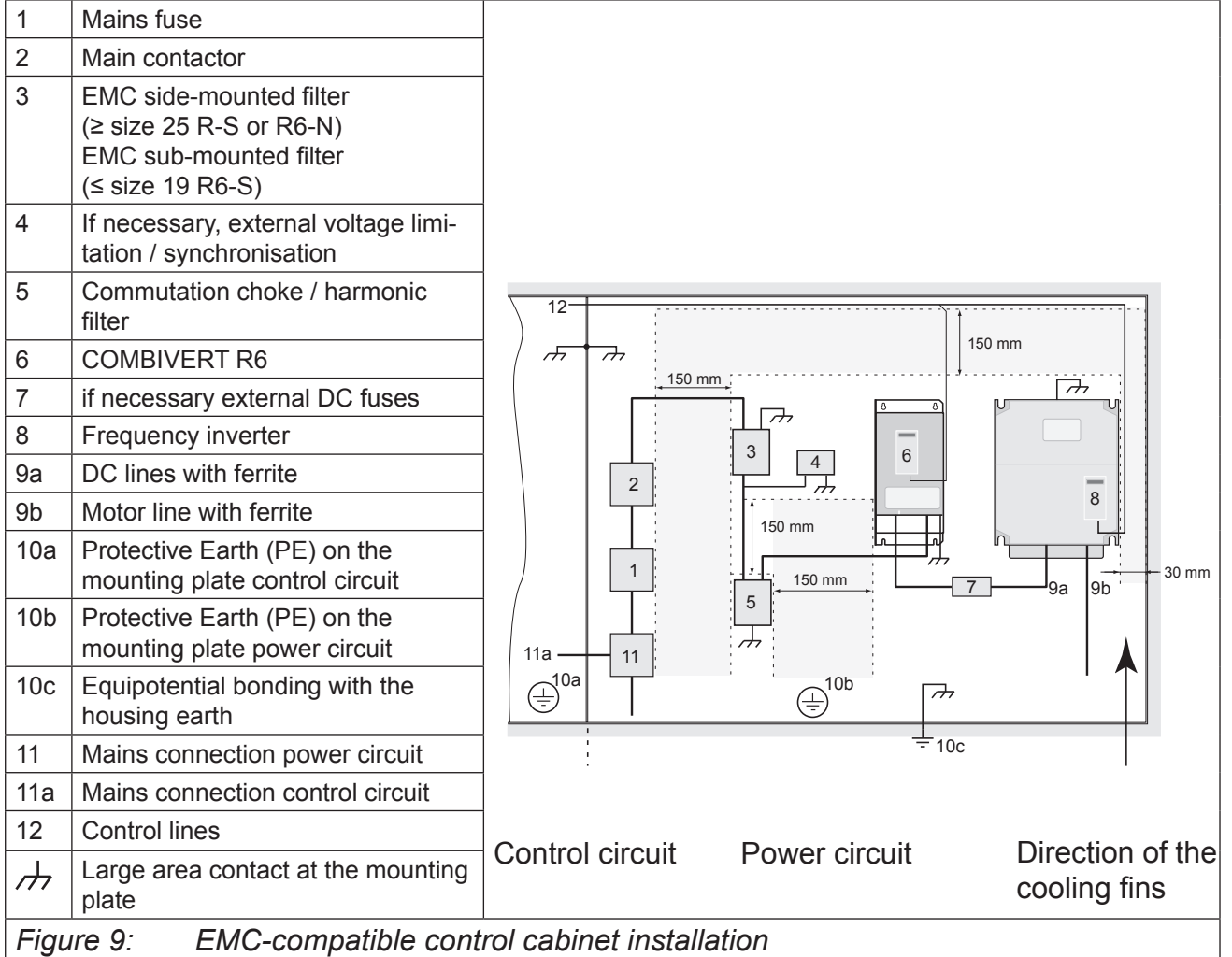



Figure 9: EMC-compatible control cabinet installation

4.2 Installation instructions

	<ul style="list-style-type: none"> • Install and ground the R6 on a stationary system. • Mist, water, or other liquids and vapors must not be allowed to permeate the device. • Allow for sufficient heat dissipation if installed in a dust-proof housing. • When operating the COMBIVERT in an explosion proof environment, install the unit in an appropriate enclosure in accordance with the local regulations and codes. • Protect COMBIVERT against conductive and aggressive gases and liquids. • For EMC reasons, the lines between R6 and commutation choke/harmonic filter must be limited to < 1m or shielding must be carried out. • The frequency inverters must be placed in the immediate vicinity of the R6-S.
--	---

4.3 Connection of the COMBIVERT R6

4.3.1 General description of inverter input terminals



	Starting current limiting
	<p>When connecting inverters to a DC bus pay attention to the internal wiring of the DC voltage inputs!</p> <p>Inverters that directly output the DC link bus to the DC terminals must be integrated into the DC bus in a way that the supply unit(s) limit the starting current. The precharging must be completed within ten seconds.</p>

	Maximum DC link capacity
	<p>The maximum DC link capacity can be calculated by adding the DC link capacities of all inverters in the DC bus. The supply source (supply unit or inverter with AC input) must be suitable for this value.</p>

Terminals	Description of terminals at KEB inverters
++, --	DC voltage input with starting current limiting; usable as output only if all units supplied by the DC bus have a starting current limiting at the DC voltage input.
+(PA), -	DC voltage output with starting current limiting; usable as input only if the starting current is limited by the supply source.
PA, PB	Connection for braking resistor; optionally only if a braking transistor is installed
L1, L2, L3	Mains input 3-phase

Type A1: AC/DC inverter	Type B1: AC inverter	Type C1: DC inverter
Type A2: AC/DC inverter	Type B2: AC inverter	Type C2: DC inverter
<p>This type can be supplied by mains and by DC circuit. The starting current limitation is designed after the input terminals. When used as output parallel connected inverters must have an own starting current limiting at the DC voltage input. Observe the max. load current.</p>	<p>This type can be supplied by mains. In consideration of the DC link capacity the DC voltage terminals can be used as output. When used as input ensure that the starting current is externally limited.</p>	<p>This type is only a DC inverter with starting current limiting. The DC inverter can be combined with all other types in consideration of the maximum DC link capacity.</p>
<p>Figure 10: General description of the input terminals at KEB inverter</p>		

4.3.2 Connection terminals of the power circuit

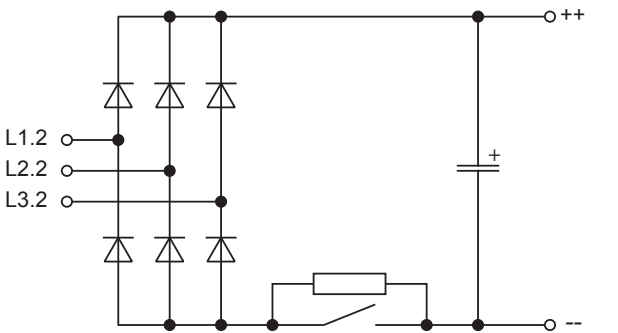
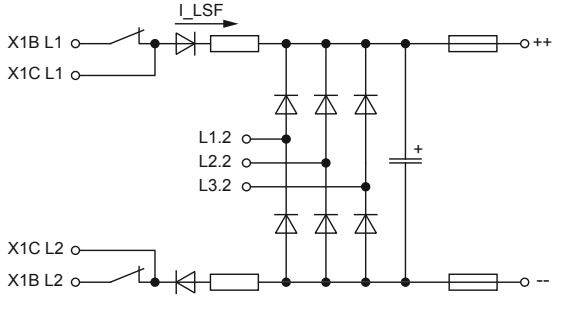
	<p>All terminal strips meet the requirements on EN 60947-7-1 (IEC 60947-7-1)</p>
	<p>View of power supply and regenerative units The terminals of a power supply and regenerative unit can be input or output dependent on the actual operating status (power supply or regeneration). For standardization, the line side is always regarded as input and the DC voltage side is always regarded as output.</p>
<p style="text-align: center;">Equivalent circuit diagram for R6-S in E housing</p> 	<p style="text-align: center;">Equivalent circuit diagram for R6-S in R housing with internal DC fuses</p> 
<p>Terminals</p>	<p>Description of terminals at KEB inverters</p>
<p>++, --</p>	<p>DC voltage output with starting current limiting for loading the connected inverters; usable as input for regenerative operation. If inverters with mains supply of type A1 or A2 (see 4.3.1) are available in the DC bus, these may be switched to mains only after loading the DC bus. Note the maximum DC link capacity or decoupling diodes!</p>
<p>L1.2, L2.2, L3.2</p>	<p>Mains input 3-phase coming from the commutation choke</p>
<p><i>Figure 11: Description of the input terminals of the COMBIVERT R6</i></p>	

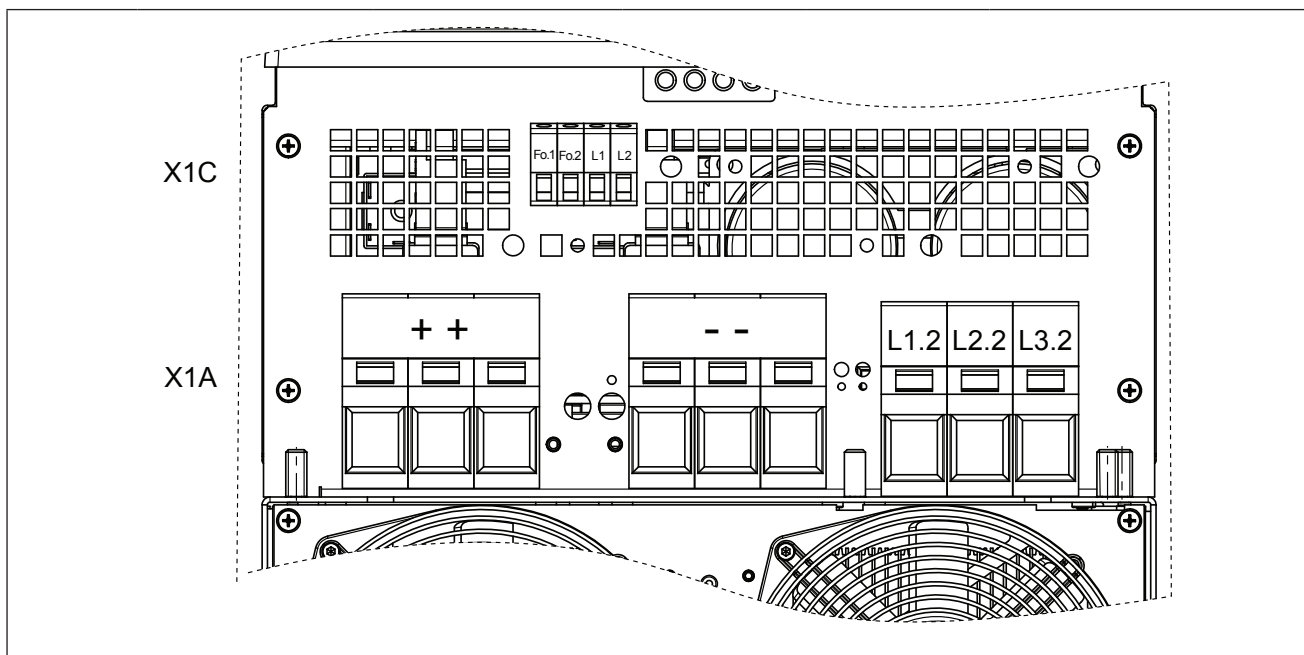

Terminal	Name	Function
X1A	L1.2, L2.2, L3.2	3-phase mains connection to the commutation choke
	++, --	DC voltage output with starting current limiting; Connection for the inverter, the connection terminals are each internally connected in parallel.
X1C	Fo.1, Fo.2	NC contact for safety monitoring (250 Vac / 2A, 24 Vdc / 0.4A ¹⁾) precharging
	L1, L2	
PE		Connection for shielding /earthing

¹⁾ Min. 20 V / 30 mA

Type and cross-section of the terminals	Conductor cross-section [mm ²]		Tightening torque	
	min	max	Nm	lb inch
Screw terminals (8mm internal hexagon)	35	95	15...20	175
Screw terminals Fo.1, Fo.2, L1, L2 (slit)	0.5	16	1.5...1.8	11...20
Stay bolt M10	Stay bolt for ring thimble 10 mm		15...25	133...220

Figure 12: Connection terminals of the power circuit

	Unused terminals must be tightened with the preset torque!
	Mains potential may be at terminals X1A, X1B or X1C (see the following chapter)!

4.3.3 Connections of the control board

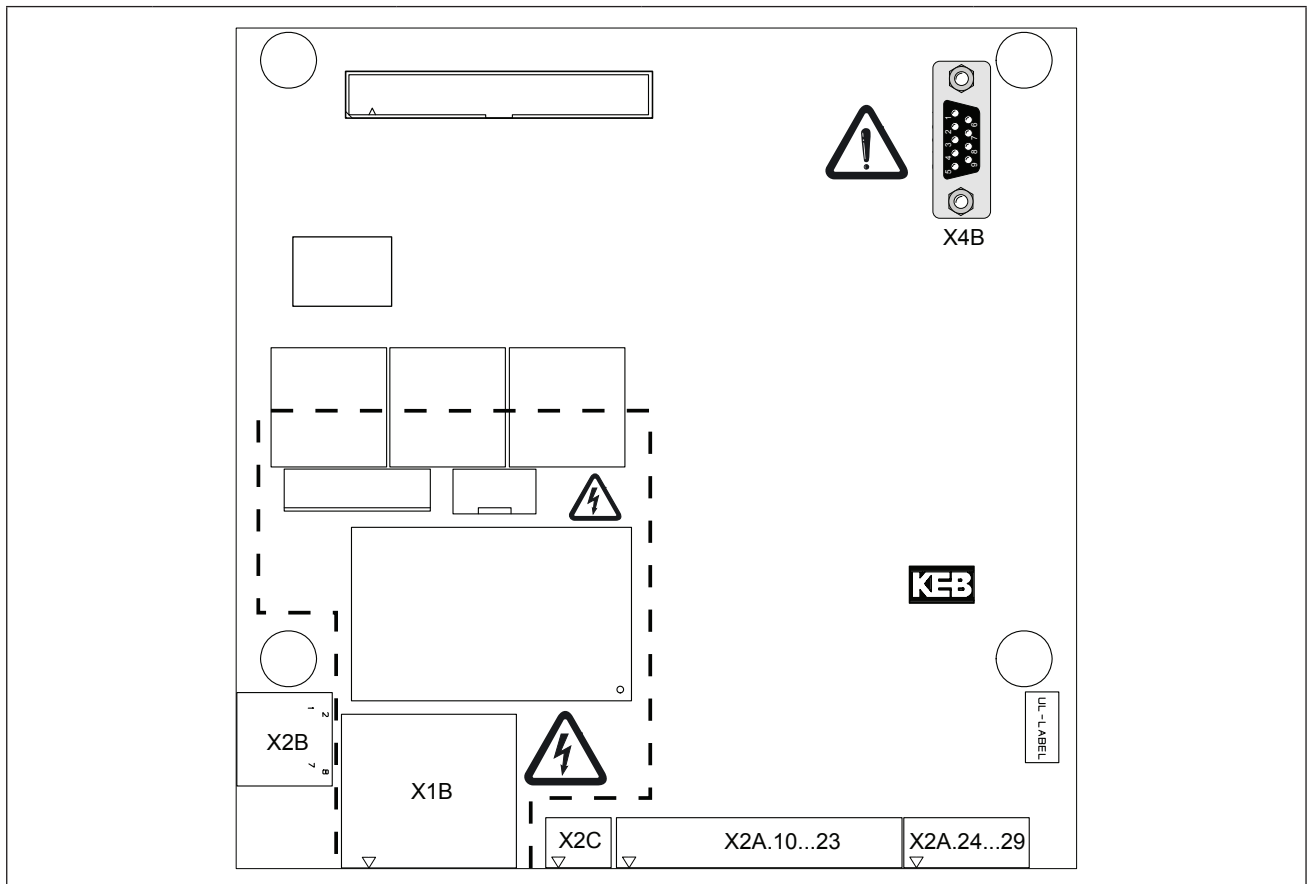

Terminal	Function			
X1B	Connection line contactor and precharging		⚠ Mains voltage potential!	
X2B	Connection for synchronization line			
X2C	Activation of the line contactor self-holding			
X4B	HSP5 operator interface		⚠ No direct PC connection	
X2A	Control terminal strip		⚠ Install control and mains cable separately!	
Terminal	Conductor cross-section [mm ²]		Tightening torque	
	min	max	Nm	lb inch
X1B	0.2	6	0.7...0.8	7
X2A	0.14	1.5	0.22...0.25	1.9...2.2
X2C	0.14	1.5	0.22...0.25	1.9...2.2

Figure 13: Connection terminals of the control board

	Unused terminals must be tightened with the preset torque!
--	--



For UL approval the following values should be observed for X1B:
 $U_{in} = 23...30\text{ V}$ or 230 Vac
 $I_{in} = 0.01...2\text{ A}$ or 2 A .
 Precharging must be carried out via the terminal X1C!

4.3.4 Connection of the synchronization unit

RJ45 socket for phase synchronization and temperature sensor	No.	Name	Function
	X2B.1	t1	Connection for temperature sensor (option)
	X2B.2	t2	
	X2B.3	U13_syn	Synchronization phase 1 / 3
	X2B.4	–	reserved
	X2B.5	U21_syn	Synchronization phase 2 / 1
	X2B.6	–	reserved
	X2B.7	U32_syn	Synchronization phase 3 / 2
	X2B.8	–	reserved

Figure 14: RJ45 socket for phase synchronization and temperature sensor

4.4 Connection power unit R6-S with UL

4.4.1 Power supply and regenerative operation at inverter current \leq inverter current of one COMBIVERT R6-S with UL

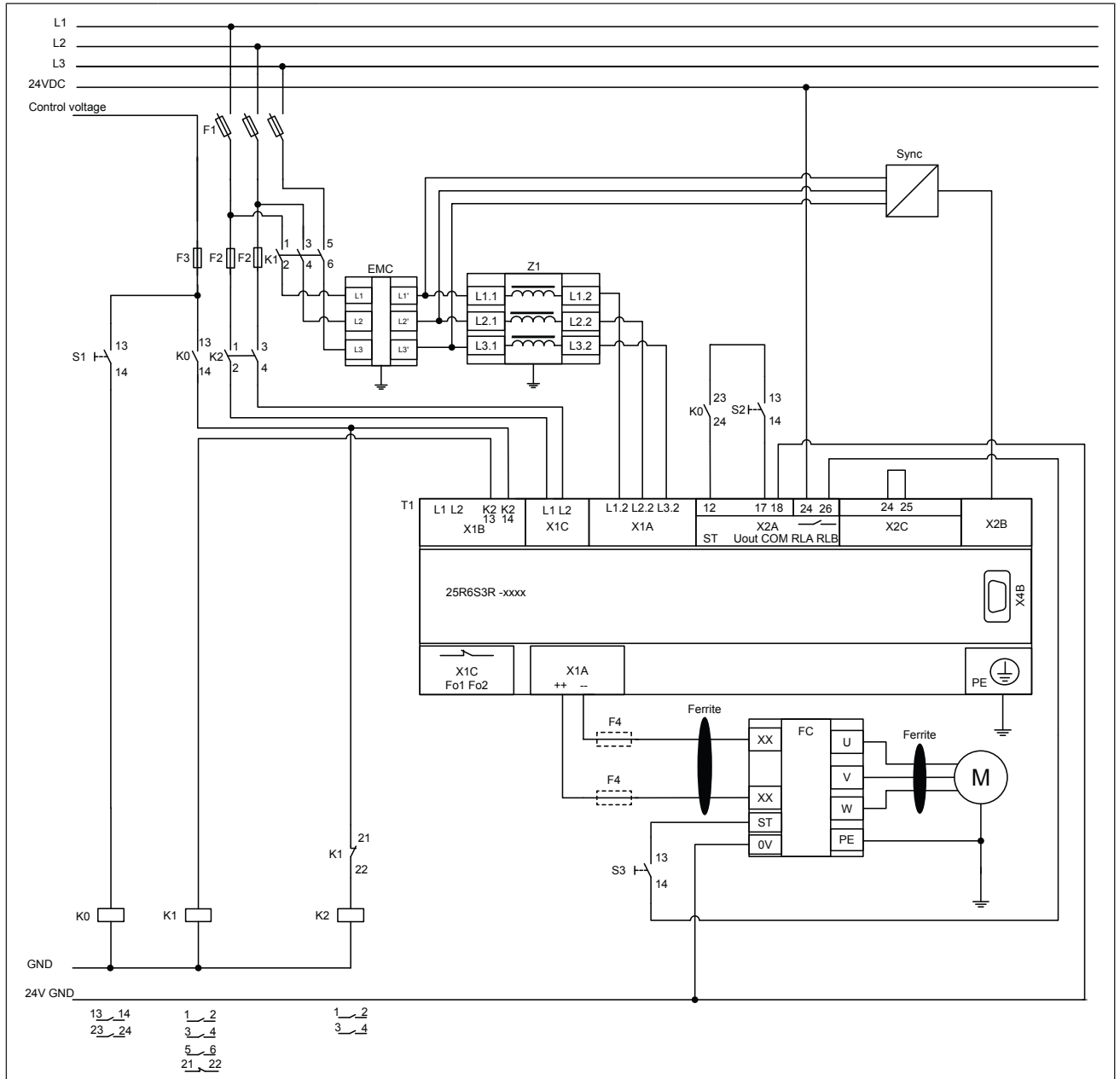

F1	Mains fuses type aR/gR	
F2	10A fuse gG/gL or automat characteristic K	
F3	10A fuse gG/gL	
F4	DC fuses type aR/gR (optional)	The cable cross section as well as the DC fuses must be dimensioned to the DC rated current of the load (see technical data of the inverter).
S1/K0	Power on/off	
S2/S3	External control release	
K1	Line contactor with auxiliary contacts	

continued on next page

K2	Pre-charging contactor (400 V / 12 AAC3)	
Sync	Synchronization unit (max. length of the phase lines 1 m)	
Z1	Commutation choke / harmonic filter	
t1	Regenerative unit COMBIVERT R6-S	
	X1A	Power circuit terminals
	X1B	Connection for line contactor
	X1C	Connection for precharging and DC fuse monitoring
	X2A	Control terminal strip (X2A.12: control release; X2A.17: voltage output)
	X2B	Connection for synchronization line
	X2C	Activation of the self-holding of the load shunt relay
EMC	EMC filter	
M	Motor	
FC	Frequency inverter	
K0	Switch on relay	
	Ferrite (optional)	

Figure 15: Power supply and regenerative operation at inverter current \leq current of one COMBIVERT R6-S

NOTICE

Destruction of the regenerative unit!

- ▶ A load draw may be done only if relay 1 is active.
- ▶ In case of failure disconnect the line contactor with S1/K1 from the supply system.

4.4.2 Power supply and regenerative operation at parallel operation with one frequency inverter

	<p>More information and a detailed wiring diagram can be found under the following link: ti_wiring_r6s_diode_fu_0501_0001_gbr.pdf</p>	
--	--	--

4.4.3 Power supply and regenerative operation at parallel operation with a second regenerative unit

	<p>More information and a detailed wiring diagram can be found under the following link: ti_wiring_r6s_para_r6s_0501_0002_gbr.pdf</p>	
--	--	--

	<p>Parallel operation When connecting in parallel operation, the parameter defaults record must be changed. See application instructions R6-S under „Special Functions for the parallel connection“.</p>
--	---

4.4.4 Brief Description of the Pre-Charging Sequence

There are three switches coming from the external controller.

S1 engages the contactor K0, which sub-sequentially engages contactor K2 for system pre-charging. This should be activated first.

S2 enables the R6 unit given that K0 is already engaged.

S3 enables the F5 drive given that there is not fault on the R6 unit.

Sequence of events:

1. S1 switch is closed by the external controller, closing the K0 contactor.
2. K0 13-14 (NO) closes, sending the control voltage (120VAC) to X1B.14 and through K1 21-22 (NC) to the K2 pre-charging contactor coil. Also K0 23-24 (NO) closes, allowing S2 to enable the R6 unit when switched by the external controller.
3. K2 pre-charging contactor closes, allowing L1 and L2 to connect with pre-charging terminals X1C L1 and L2.
4. Once pre-charging is complete, X1B.13 activates contactor K1. K1 closes, allowing L1, L2, and L3 to connect with the main power terminals on the R6 and the auxiliary contact K1 21-22 opens, opening K2 pre-charging contactor so the pre-charging is disconnected.

4.5 Connection of the control board version S

4.5.1 Assignment of the control terminal strip X2A

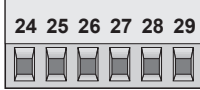
X2A					
					
Conductor cross-section 0.14...1.5 mm ² , tightening torque 0.22...0.25 Nm					
PIN	Function	Name	Default	Description	Specifications
10	24V input	Uin		External supply of the control board	21.6...26.4 VDC / 1A
11	Mass	COM		Reference potential	
12	Digital input 1	ST		Control release / reset	Ri: 4.4 kΩ
13	Digital input 2	I1	Set selection	programmable	
14	Digital input 3	I2	Set selection	programmable	
15	Digital input 4	I3	Ext. error	programmable	
16	Digital input or output	I/O (I4)		Active signal (connection of all R6 at parallel operation in master-slave mode)	
17	24 V output	Uout		Voltage supply for in- and outputs	approx. 24 V / max. 100 mA
18	Mass	COM		Reference potential	
19	Digital output 1	O1	DC >600 V	Transistor output (DC > CP.19)	I _{max} : 25 mA
20	Digital output 2	O2	Error message	Transistor output (error message)	I _{max} : 25 mA
21	Analog output	AN-OUT		Difference to mains frequency (CP.18)	0...±10 V / max. 5 mA
22	24 V output	Uout		see terminal 17	
23	Mass	COM		Reference potential	
24	Relay 1 / NO contact	RLA	Ready for operation (no error)	Relay output Ready signal (status "Stb" or "rEGEn")	max. 30 VDC *) 0.01...2 ADC
25	Relay 1 / NC contact	RLB			
26	Relay 1 / switching contact	RLC			
27	Relay 2 / NO contact	FLA	DC > 600 V	Relay output (DC > CP.19)	max. 30 VDC *) 0.01...2 ADC
28	Relay 2 / NC contact	FLB			
29	Relay 2 / switching contact	FLC			

*) The relay outputs must be operated with max. 48 VDC protective separation voltage to guarantee the CE standard. After consultation with KEB a current of max. 2ADC is permissible for 120 VAC (depending on the switching capacity etc.).

4.5.2 Assignment of the socket X2B



RJ45 socket for phase synchronization and temperature sensor	No.	Name	Function
	1	T1	Connection for temperature sensor (option)
	2	T2	
	3	U13_syn	Synchronization phase 1 / 3
	4	–	reserved
	5	U21_syn	Synchronization phase 2 / 1
	6	–	reserved
	7	U32_syn	Synchronization phase 3 / 2
	8	–	reserved

Figure 16: RJ45 socket

The connection is made with a sync cable 1:1 with the socket X2B, X2C or X2D at the commutation choke or synchronization unit.

4.5.3 Assignment of the terminal block X2C

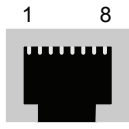
		
Conductor cross-section 0.14...1.5 mm ² , tightening torque 0.22...0.25 Nm		
PIN	Function	Description
24	Bridge between pin 24 and pin 25	Activation of the self-holding of the line contactor
25		
26	not assigned	-

4.5.4 Wiring example

In order to prevent a malfunction caused by interference voltage supply on the control inputs, the following directions should be observed:

 EMC	• Use shielded/drilled cables
	• Lay shield on one side of the inverter onto earth potential
	• Lay control and power cable separately (about 10...20 cm apart); lay crossings in a right angle

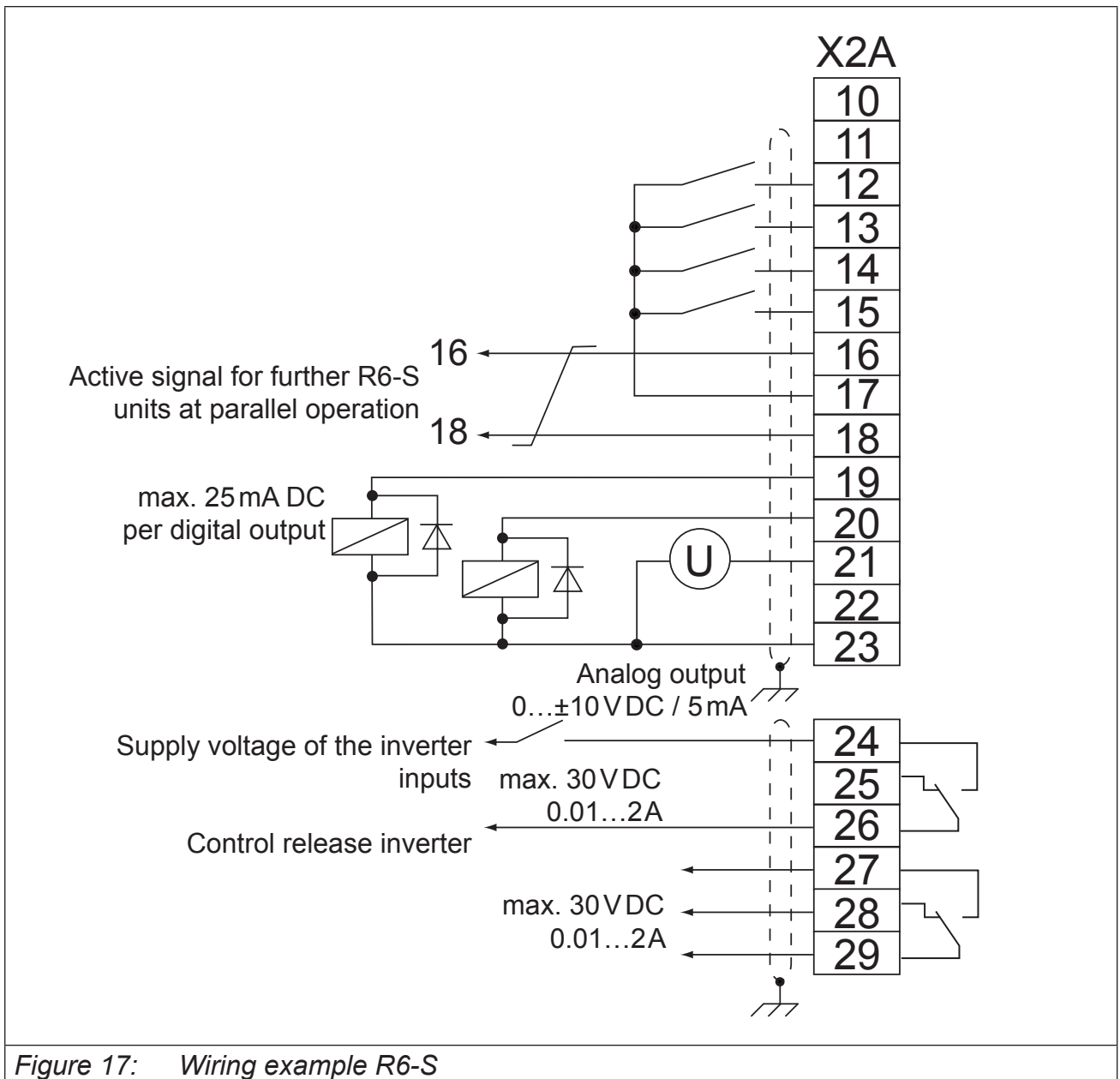

Figure 17: Wiring example R6-S

5. Operation of the Unit

5. Operation of the Unit

5.1 Operator





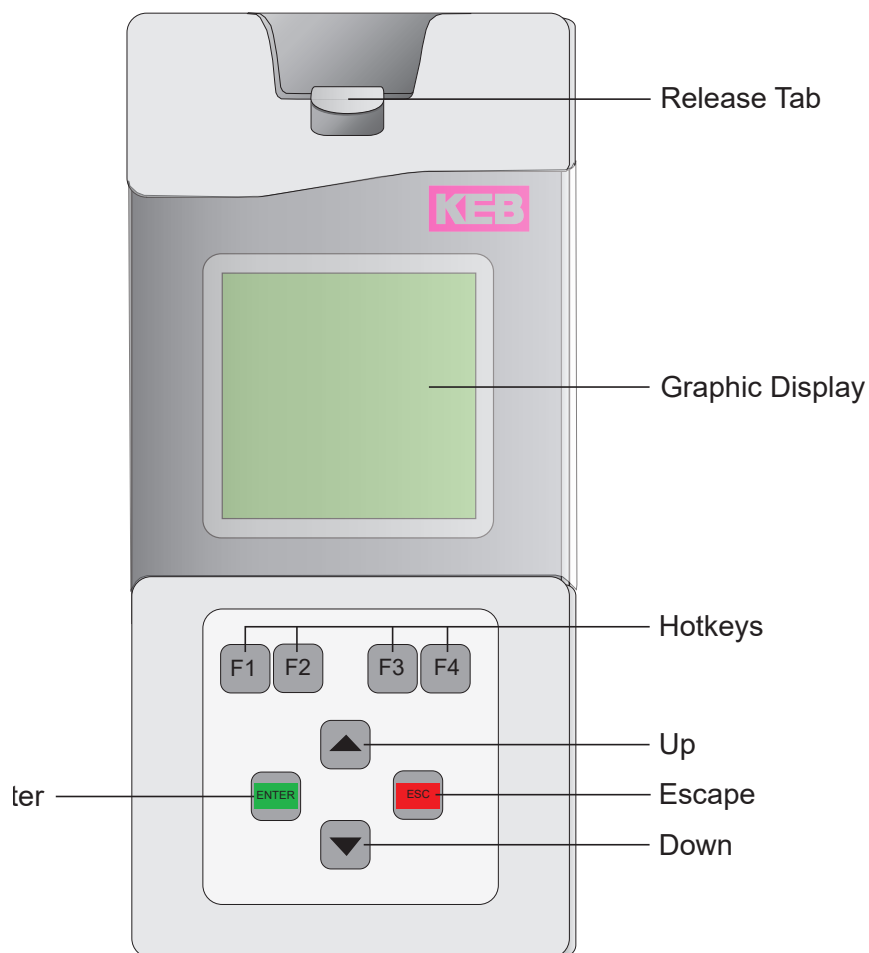

As an accessory a keypad operator can be installed. A digital operator (00.F5.060-K001) is provided with every regen unit. To prevent malfunctions, the COMBIVERT must be brought into No Operation (nOP) status before connecting or disconnecting the operator (de-activate the enable input). When starting the COMBIVERT R6, it is started with the last stored values or factory settings regardless of whether the operator is installed or not.



Do not place KEB F5 Elevator Drive Keypad on the R6, it is not compatible and will not go past the loading screen or display E.CArD.



5.2 Keyboard

Button	Name	Function
 	Up/Down	Increment/decrement through menu or values
	Enter	<ul style="list-style-type: none"> - Selects a parameter or group - Enters Edit Mode - Save parameter setting
	Escape	Backs out of parameter group or exits Edit Mode
 	Hotkeys	<ul style="list-style-type: none"> - Keys correspond to display LCD text above - Allows a user to quickly jump menus

If an error occurs during operation, then the actual display is overwritten by the error message. The error message in the display is reset by ENTER.



If the error has been cleared from the keypad display, but the red LED is flashing on the R6, there is still an active fault. In order to reset the error itself, the cause must be corrected and a power-on reset must be made. Note: The R6 unit will attempt to reset errors on its own based on the auto reset parameter.

5.3 Operation with PC and system software COMBIVIS 6

Instructions for the installation and operation of the system software COMBIVIS can be taken from the appropriate software instruction. See keblog.com/elevator-support for videos.

5. Operation of the Unit

5.4 Switch-on procedure

The COMBIVERT R6-S is initialized after connection of the power supply. The power circuit identification is checked first. If an invalid power unit is recognized, error "E.Puci" (Power unit code invalid) is released and displayed in the operator. This error cannot be reset, the power circuit must be checked.

The COMBIVERT R6-S changes into synchronization phase if a valid power circuit is recognized. The following procedures happen one after another during this synchronization phase:

- Inspection of correct synchronization connection (error "E.nEt" is triggered, if the synchronous signal is missing)
- Inspection of the phase allocation of synchronous signals to the mains phases. Error "E.SYn" is triggered if a phase is missing or in case of phase allocation failure.

The actual line frequency and the mains voltage is determined after successful synchronization. The correct connection of the COMBIVERT R6-S is now ensured. If the control release (terminal ST) is set, the COMBIVERT R6-S starts independently with the normal operation. Depending whether regenerative requirement is available, the COMBIVERT R6-S is in status "rEGEn" or "Stb".

Status "standby/Stdby"

COMBIVERT R6-S detects a typical voltage level in the DC link circuit of the connected frequency inverter (motor operation) and keeps the modulation signals of the regenerative unit deactivated.

Status "regen active/rEGEn"

If the DC voltage in the DC link (CP.09 or ru.19) exceeds the value of the regeneration level referring to the reference value ru.18, the modulation signals are activated and the unit changes into regenerative operation. Furthermore the regenerative unit is switched active, if regenerative operation is requested by an additional installed COMBIVERT R6-S in the system (master/slave operation).

5.5 Parameter summary

The CP parameters are the parameter selections defined by KEB. You need an application manual in order to get access to the entire parameter list.

Display	Parameter	Setting range	Resolution	Factory
CP.00	Password	0...9999	1	–
CP.01	Inverter State	–	–	Read Only
CP.02	Actual Line Frequency	–	0.1 Hz	Read Only
CP.03	AC current L1	–	0.1 A	Read Only
CP.04	AC current L2	–	0.1 A	Read Only
CP.05	AC current L3	–	0.1 A	Read Only
CP.06	Act. (Actual) DC Utilization	–	1%	Read Only
CP.07	Peak DC Utilization	–	1%	Read Only
CP.08	DC Current	–	0.1 A	Read Only
CP.09	DC voltage	–	1V	Read Only
CP.10	Peak DC Voltage	–	1V	Read Only
CP.11	Power Module Temperature	–	1 °C	Read Only
CP.12	OL (Overload) Display Counter	–	1%	Read Only
CP.13	Actual Power	–	0.1 kW	Read Only
CP.14	Total Regen	–	1 kW	Read Only
CP.15	Total Motor	–	1 kW	Read Only
CP.16	Total Net	–	1 kW	Read Only
CP.17	Actual Net	–	0.1 kVA	Read Only
CP.18	ANOUT1 (Analog output 1) Gain	-20.00...20.00	0.01	1.00
CP.19	Comparison Level 0	+/-30000.00	0.01	550.00
CP.20	General Fault Reset	0...10	1	3
CP.21	Last Error	–	–	Read Only
CP.22	Last Error 1	–	–	Read Only
CP.23	Last Error 2	–	–	Read Only
CP.24	Last Error 3	–	–	Read Only
CP.25	Last Error 4	–	–	Read Only
CP.26	Last Error 5	–	–	Read Only
CP.27	Last Error 6	–	–	Read Only
CP.28	Last Error 7	–	–	Read Only
CP.29	Software version	–	–	2.0
CP.30	Software date	DDMM.Y	–	Read Only
CP.32	Puls (Pulse) off level	-100kW...0,0kW	0.1kW	-0.8kW
CP.33	Operating mode	0...3	1	0
CP.34	PNP/NPN Selection	PNP/NPN	–	PNP
CP.35	Kp Harm. (Harmonic) Filter	2...18	1	Variable

() Values in parenthesis correspond to size 15 R6.

5.6 Monitoring and analysis parameters

The following parameters allow the user to monitor the functionality during operation.

CP.00 Password Input

Contact KEB for password levels to access additional parameters.

CP.01 Inverter State

The status display shows the actual operating mode of the POWERBACK R6. Refer to Section 6.0 for additional descriptions and troubleshooting faults.

CP.02 Actual line frequency

After switching on, the actual line frequency is determined during the initialization phase. Slowly, changes of the line frequency during operation are recognized and displayed in CP.02. CP.02 displays the actual regenerative frequency, if the COMBIVERT R6-N is in "netof" state, i.e. mainline power has been lost. The rotating field of the mains frequency is displayed as follows: (+) right, (-) left



This value should be positive. If the value is negative the R6 unit will get a 'Synchronization error' - swap L1.1 and L2.1 legs of the incoming at the commutation choke to make the frequency positive.

CP.03 AC current L1

CP.03 displays the rms value of the current of phase L1 in amperes.

CP.04 AC current L2

CP.04 displays the rms value of the current of phase L2 in amperes.

CP.05 AC current L3

CP.05 displays the rms value of the current of phase L3 in amperes.

CP.06 DC utilization

Parameter CP.06 displays the actual load of the POWERBACK R6-N in percent. 100% represents an output current, which corresponds to the rated current of the POWERBACK R6-N. The absolute value of the load is displayed. The sign indicates the energy direction: (+) = supply, (-) = feedback

CP.07 Peak DC utilization

Parameter CP.07 stores the peak load value within an operating cycle. The highest value of CP.06 is stored in CP.07. The peak value can be cleared by pressing the UP and DOWN key or over bus by writing any value you like to the address of CP.07. Switching off POWERBACK R6-N also clears the stored value.

CP.08 DC output current

Display of the actual DC current in amperes.

CP.09 DC Voltage

Display of actual DC-Bus voltage in volts. The value is measured at the terminals "++" and "--" of the POWERBACK R6-N.

CP.10 Peak DC Voltage

Parameter CP.10 allows the user to recognize short-term peak values within an operating cycle. The highest value of CP.09 is stored in CP.10. The peak value can be cleared by pressing the UP and DOWN key or over bus by writing any value you like to the address of CP.10. Switching off POWERBACK R6-N also clears the stored value.

CP.11 Power Module Temperature

Display of the actual heat sink temperature in °C. First a pre-warning can be given via digital output if the heat sink temperature is too high, so a controlled deceleration of the unit is possible. The modulation is shut off and the unit de-activated when reaching the max. heat sink temperature, if there is no reaction to the pre-warning.

CP.12 OL (Overload) Counter

The average load of the POWERBACK R6-N can be evaluated with this parameter in order to avoid an Error Overload (time based overload). When the actual load goes above 105%, the counter begins to increment. The Error Overload is triggered, if the overload counter reaches 100%.

CP.13 Actual power

CP.13 displays the actual active power of the POWERBACK R6-N. Motor power is displayed with positive values, generated power is displayed with negative values.

CP.14 Total Regen

Counter of the total regenerated electrical energy returned to the line in kWh.

CP.15 Total Motor

Counter for the total supplied electrical energy from the line in kWh.

CP.16 Total Net

Display of the difference between supplied and regenerated energy. The sign of the value displayed indicates a net energy supply from the line (+) or return to the line (-).

CP.17 Actual Net

Display of the actual apparent power at the mains input (kVA).

CP.18 ANOUT1 (Analog output 1) Gain

This serves as a gain for the analog output 1. This output provides a signal in a range of 0...10VDC = 0...150% I_{DC} which corresponds to the DC-bus current. The gain can be adjusted with CP.18 in a range of 0...±20,00. With this parameter, the analog output signal can be adapted to individual requirements.

CP.19 Comparison Level 0

When the DC bus voltage drops below this level, the error E.EF(External Fault) will be triggered to indicate mainline voltage sag and high regenerative / supply current. Refer to section 6.2.2 for troubleshooting. This voltage threshold also controls the switching of the relay output R2. This level should be set according to the line supply:

208/230VAC supply - CP.19 = 230VDC

460/480VAC supply - CP.19 = 550VDC

CP.20 General Fault Reset



This parameter can be used to activate an auto reset counter to reset errors. NOTE: an auto reset could allow the system to resume operation at any time! Protective measures must be implemented for service personnel and machine operation to prevent injury or damage.



A value of 0 means no automatic reset. Errors can only be reset via the terminal strip or power cycle. Values of 1...10 determine the maximum number of times per hour the unit will auto reset an error. If the number of errors exceeds this value, the unit will stop with the last error. Reset will then only be possible via the terminal strip.

CP.21...28 Last error(s)

The parameters CP.21...28 display the last eight triggered errors with the exception of "Error under voltage" which is not stored. The oldest error is found in CP.28. When a new error occurs, the error message is stored in CP.21. All previous error messages are shifted by one to the next parameter. The oldest error in CP.28 is lost. The meaning of the error codes can be found in the description for CP.1.



There is a Fault Log on the LCD keypad that can display more than eight errors and can be cleared. It is recommended to use this fault log instead of CP21...28. Refer to the *A.1 Data Logging* section in the Appendix.



Same, subsequent errors are not uniquely logged. For example if the series of fault messages occurred was Error net, Error net, Error overcurrent, then the fault log would read CP.21 = Error net, CP.22 = Error overcurrent and NOT CP.21 = Error net, CP.22 = Error net, CP.23 = Error overcurrent.



The error log cannot be cleared, although jumpering X2A.15 and X2A.17 (if CP.34 = PNP, if CP.34 = NPN, then jumper X2A.15 and X2A.18) will force an Error External Fault (E.EF). This can be used to determine if any subsequent errors are the same as the fault prior to forcing E.EF or whether a new fault is occurring.

CP.29 Software Version

This parameter displays the software version. Example: Version 1.02 = 1.02

CP.30 Software Date

This parameter displays the software date in the format DDMM.Y. Example: 2012.3

CP.32 Puls (Pulse) off level

This determines the reverse power level required to switch out of regen mode and back into stand-by mode. The adjustment is in kW. This parameter does not generally require adjustment

CP.33 Operating Mode

Determines the operating mode of the unit. When more than one unit is connected in parallel (R6-S only) it is necessary to set one unit as the master and the remaining unit(s) as slave(s). NOTE: The R6N cannot be used in parallel, so only settings 0 and 1 can be used.

- 0: Master with commutation choke
- 1: Master with harmonic filter
- 2: Slave with commutation choke
- 3: Slave with harmonic filter

CP.34 PNP/NPN Selection

This parameter adjusts the inputs for the type of signals, PNP (sourcing) or NPN (sinking).

CP.35 Kp Harm. (Harmonic) Filter

Proportional current gain in regen mode when using harmonic filter. Does not apply when using commutation choke.

The default value of 10 should be sufficient, particularly with high impedance line (eg. isolation transformer). Contact KEB if further adjustment is needed.

Troubleshooting and Diagnostics

6. Diagnosis and Troubleshooting

6.1 Status Display: Status and Error Messages

6.1.1 Status Messages

The following are status messages for CP.1:

Status Messages	
regen active/ rEgEn	Regen active (regeneration operation)
base block/BBL	base-block time, Unit is blocked from operation for a short period - precedes all errors.
no operation/ nOP	"no Operation" the enable input is not activated, output modulation switched off
net off	"net off" Line power failure; Regen operation mode is possible
Standby/Stdby	The unit is enabled but in stand-by operation (motoric operation)
SYn	Phase synchronization mode, checks connection and phase angle of the line voltage
fault reset level reached	Fault reset level reached

6.1.2 Fault Log

The LCD display has a Fault Log which displays faults that occur and can be cleared. The top fault is the newest fault while any older ones follow it below. To access the Fault Log, starting from the CP Parameter List:

- Press F1 for Menu
- Select Fault Log

To clear the fault log, press F4 for File while in the Fault Log and press Enter. Then press Escape, and it should say "Empty Log".



6.1.3 Error Messages

The following are error messages for CP.1:

Error Messages	
8: ERROR power module temperature	Error: Overtemperature of power module. Error can only be reset at E.nOH, if the temperature has dropped by 5°C. Insufficient air flow at the heat sink (soiled), ambient temperature too high, vent clogged.
31: ERROR External Fault	Error: External Fault. The R6 has been programmed to trigger this error for assistance in identifying high regenerative/supply current and line voltage sag - refer to CP.19 settings and section 6.2 for troubleshooting. Additionally, the error can be triggered by an external device through one of the digital inputs. This error can also be triggered manually by setting a temporary jumper across X2A.15-X2A.17(refer to CP.21 - CP.28 for use with the fault log.)
40: ERROR line frequency	Error: Main Line Frequency out of tolerance.
15: ERROR load shunt fault	Error: Load-shunt relay has not picked up, occurs for a short time during the switch-on phase, but will automatically reset immediately.
3: ERROR net	Error: Line, one or more phases are missing
36: no ERROR overheat	Error: NO Over Heat, over-temperature condition not present (E.OH error can be reset)
17: no ERROR overload	Error: NO Over load, cooling period after E.OL is over, error can now be reset
4: ERROR overcurrent	Error: Over current, output current too high or ground fault
8: ERROR overheat pow. mod.	Error: Over temperature, overheating of the heat sink (see "technical data")

6: ERROR overheat internal	Error: R6 Unit interior temperature too high, temperature in the interior > 95 °C
16: ERROR overload	Error: Over Load, the actual load was greater than 105% and the overload timer timed out.
1: ERROR: over voltage	Error: Over Voltage, DC bus voltage is too high, > 900VDC
49: ERROR pow. unit code inv.	Error: Power unit identification is invalid
50: ERROR pow. unit changed	Error: Power unit change. Refer to parameter CP.31.
59: synchronization error	Error: Synchronization, connection of line phasing is not correct
2: ERROR under voltage	Error: Under voltage, DC bus voltage too low
12: ERROR power unit	Error: General power circuit error
33: ERROR Power Flicker Detection	Error: Power flicker detected, power failure (phase)

Troubleshooting and Diagnostics

6.2 Troubleshooting

6.2.1 Troubleshooting Error Messages

Fault	Cause	Solution
Synchronization error (E.Syn) Error Code: 59	Line frequency calculated incorrectly	Check CP02 this value must be positive 60Hz If it is -60Hz swap L1.1 and L2.1 (incoming side) of the commutation choke or harmonic filter wires If it is 0Hz, verify if mainline power is balanced phase to phase and phase to ground, ensure there is no missing phase, then swap L1.1 and L3.1 (incoming side) of the commutation choke or harmonic filter wires.
Error net (E.nEt) Error Code: 3	Refer to Sections 4.4.2 to determine the corresponding wiring of the regen unit. Wiring Scheme A Loss of a line phase Noise/EMI	This error can occur if there is too much current on the regen unit check to see if there is an Error Overcurrent or Error Overload when this fault occurs and troubleshoot those errors Verify balanced three-phase supply. Check all connections going to the R6; re-land if necessary. Ensure proper ground connections. If there is an iso-transformer installed, verify its wiring making sure the secondary is in wye configuration and that center ground is connected (Typically labeled "X0"). Refer to Noise/EMI in Section 6.2.2.
Error overcurrent (E.OC) Error Code: 4	Ground fault or short Noise/EMI Supply or regenerative current too high	Check for any loose or missing power connections. Check for similar errors on the (F5) Elevator Drive indicating a ground fault, short, or excessive current. This may indicate the cause of the fault is occurring due to an issue with the drive, motor contactor, or motor. Refer to Noise/EMI in Section 6.2.2. Check to see if the utilization in CP.6 is high; check CP7 peak utilization. Refer to High Regenerative/Supply Current in Section 6.2.2. Verify sizing with controller manufacturer.
Error line frequency (E.FnEt) Error Code: 40	Line frequency out of range (57-60Hz, based on 60Hz nominal line). Generator power operation causes voltage frequency swing. Noise/EMI	If error is always active, check CP02 if it is 60Hz, if not refer to E.SYN Fault Monitor Main Line Frequency at CP.2. Output frequency from generator may be too high/low and may change as various other loads come on/offline. Refer to Noise/EMI in Section 6.2.2.

Fault	Cause	Solution
Error power unit changed (E.PuCH) Error Code: 50	The voltage class of the line supply has changed since last power on and must be confirmed (cycling power will not clear).	Reset by reasserting the value in Sy.03 (password restricted). WARNING: Improper use of Sy.03 may corrupt and default the unit. Contact KEB for assistance.
Error overload (E.OL) Error Code: 16	Supply or regenerative current too high	Check to see if the utilization in CP.6 is high; , check CP7 peak utilization. Refer to High Regenerative/Supply Current in Section 6.2.2. Verify sizing with controller manufacturer.
Error DC Bus charge fault (E.LSF) Error Code: 15	If the error does not reset itself after power up and the fault remains, then the following causes may be applicable: Load-shunt defective Input voltage wrong or too low High losses in the supply cable	This can happen due to noise on the X2A terminal This error can occur when power is removed to the R6 unit Verify line supply or transformer output supply and that there is not excessive sag or brown-out conditions.
Error power unit (E.PU) Error Code: 12	Error on the power stage.	General error on the power stage. If error is always active, check CP02 if it is 60Hz, if not refer to E.SYN Fault. Check grounding of the transformer. If the error is always active, then the unit must be sent in for evaluation. If intermittent, it may indicate excessive line sag conditions.
Error undervoltage (E.UP) Error Code: 2	DC bus level is too low Undervoltage value: 150 VDC	This error can occur if there is too much current on the regen unit check to see if there is an Error Overcurrent or Error Overload when this fault occurs and troubleshoot those errors Likely indicates poor power quality. Verify line input voltage. Sagging voltage or loss of phase could cause E.UP error. Check all grounding including X0 of transformer.

Troubleshooting and Diagnostics

Fault	Cause	Solution
<p>Error Overpotential (E.OP) faults on F5 Elevator Drive</p>	<p>Regen unit unable to regen back to the line; CP.1 status not in 'regen' status during generating operation:</p> <p>Enable input not present (CP.1 Status = No Operation or NOP)</p> <p>Input logic not set correctly to recognize enable input (i.e. CP.34 = PNP vs. NPN)</p> <p>Regen unit in active fault;</p> <p>DC bus fuse(s) open.</p>	<p>Verify enable input at X2A.12. When active under normal operation, the CP.1 status should be either 'Standby/Stby' or 'Regen/rEgEn'.</p> <p>Verify CP.34 setting according to input type.</p> <p>PNP: inputs must be +24VDC to be active.</p> <p>NPN: inputs must be at 0VDC to be active.</p> <p>CP.1 status displays fault message or if the fault message has been cleared from the screen by pressing ENTER on the operator keypad, a flashing red indicator LED on the R6 indicates an active fault remains. Reset (X2A.13) or resolve the cause of the fault.</p> <p>If the fault has been automatically reset, the last fault can be viewed in the fault log, CP.21. If it is unclear whether a fault actually occurred, refer to the note under CP.21...28 to force a specific fault in order to determine if a new fault is occurring.</p> <p>The DC bus fuse(s), internal to the R6, can be checked visibly whether they are open and replaced as needed (Refer to Replacing DC Bus Fuses Section for location and testing of fuses). Before checking, ensure all safety measures necessary including powering down the unit from the mains disconnect and locking it out.</p>
<p>External Fault (E.EF) / A.EF)</p> <p>Error Code: 31 / Error Code 90</p>	<p>Can be triggered by external device or use of jumper at X2A.15-X2A.17.</p> <p>High regenerative / supply current or excessive line voltage sag causing the DC bus voltage to drop below the level set in CP.19.</p>	<p>Lower CP19 if needed, for incoming power of 208-230VAC lowest value can be 200 and 460-480VAC lowest value can be 500.</p> <p>Refer to section 6.2.2 regarding high regenerative / supply current and excessive line voltage sag.</p>

Fault	Cause	Solution
<p>Error power flicker detection (E.pfd)</p> <p>Error Code: 33</p>	<p>Unstable incoming power.</p> <p>Will also occur when switching between mainline and generator power. This is due to the change in voltage sources as well as the generator's unstable voltage output when it is first turned on and hasn't reached its full operating speed.</p>	<p>Investigate mainline power issues, check connections at the commutation choke and R6.</p> <p>Check CP02 if it is 60Hz, if not refer to E.SYN Fault</p> <p>Delay the engagement of the main disconnect long enough to allow the generator to reach full speed and output a steady voltage. This may involve a timing adjustment of a contactor connected to the mainline disconnect; may need to work with the building electrician to achieve this.</p> <p>The only way to clear this fault is by cycling power. It may be necessary to leave the R6 powered off for a few minutes before re-applying power.</p>

Troubleshooting and Diagnostics

6.2.2 Troubleshooting Operational Problems

Problem	Cause	Solution
High regenerative or supply current	High nominal motor current	Check the current on the F5 Elevator Drive. Determine the cause of the high motor current, and troubleshoot accordingly.
	High peak motor current during acceleration/deceleration	Check the peak current on the F5 Elevator Drive. Determine the cause of the high peak motor current and troubleshoot accordingly. Potentially adjust acceleration/deceleration rates.
	Low input voltage/Excessive line sag	A decrease in input voltage causes a corresponding increase in supply current. Monitor CP.9 to see if the DC bus voltage is dropping below the CP.19 value during operation. Then, verify and ensure that the incoming line voltage is not sagging during operation.
	Overutilization	Check CP.6 and CP.7. If CP.7=160%, then the regen unit is being overutilized.
Noise/EMI causing intermittent regen faults (Error overcurrent, Error net, Error line frequency).	Imbalance line supply, Grounding	<p>Line supply or transformer secondary MUST be a balanced, center-grounded wye connection.</p> <p>Check for actual connection of center-ground.</p> <p>Measure phase-ground voltage at R6; they should be balanced.</p> <p>Measure phase-phase voltage at R6; they should be balanced.</p>
	Noise/EMI, Grounding	<p>Add additional R6 ferrite ring to DC bus connections. Installing the incorrect type of ferrite ring will not have an effect mitigating noise.</p> <p>Verify correct grounding connections and techniques as well as panel wire layout.</p> <p>Check for any loose or missing ground connections.</p> <p>Ground conductors must be minimum #4 AWG or thick ground strap.</p> <p>DC bus wires (++, - -) should be tied together.</p> <p>Any DC, AC, Motor leads or switching power (e.g. brake or contactor coil) wires must be physically separated from each other and not run together.</p> <p>Add additional ferrite ring(s) around all motor lead connections at drive output (additional ferrites around individual motor leads is not necessary).</p>
Fault reset level reached (FrLr)	Automatic fault reset counter limit was reached.	Must cycle ST. See CP.20 for further details.

A. Appendix A

A.1 Data Logging

The KEB LCD regen keypad has internal data logging capabilities built in. The function can be activated from the 'Data Logging' menu under the Main Menu of the keypad. Once enabled, up to 10 trending parameters can be logged at a variable sample rate, as well as up to 4 fast-scanning parameters triggered by a fault in the regen unit. An SD card is required to store data and cards up to 8GB are acceptable to use. It is recommended the date and time are set in the keypad before proceeding to get an accurate time stamp.

1 - Setup

Datalogging Menu

Generic Parameters - Select up to 10 parameters for trending data.

General Logging - Enables/Disables General data trending. Takes a data point every cycle (.5s fixed sample time x Time Multiplier). Once enabled, General Logging immediately starts recording the parameters selected from the 'Generic Parameters'.

Fault Parameters - Select up to 4 parameters for fast-scanning fault data.

Fault Logging - Enables/Disables fast-scanning Fault logging. Event is triggered by a fault in regen unit. Once enabled, Fault Logging will start recording the parameters selected from the 'Fault Parameters' when triggered.

Base Block Checking - Base Block (BBL) is a message in the regen unit indicating the IGBT's have been locked for safety reasons. This occurs every time the unit is disabled or before a fault.

'On' - BBL will trigger an event and a fault file will be created.

'Off' - BBL is ignored and will not trigger an event. It is recommended to set this to 'Off' for most applications so a file is not created at the end of every run.

Sample Time - Base sample time for Fault Logging. Default is 1000 us.

Trigger Value - Percentage of time that will be displayed before the event occurred (ie if set to 40%, then 40% of the data will be displayed before the event and 60% will be displayed after). This can be adjusted to see more data either before or after the event occurs. Default is 50%.

Time Multiplier - Multiplier of the base sample time for General Logging. Default is 2.

Pre-Trigger Source - Allows the event for Fault Logging to be triggered by a digital input instead of a fault. Enter the decimal number for the desired input. Please note that the inputs have defined default functions. Default is 0.

Input 1 (terminal X2A 13) - '16'
 Input 2 (terminal X2A 13) - '32'
 Input 3 (terminal X2A 13) - '64'
 Input 4 (terminal X2A 13) - '128'
 Input A (internal) - '256'
 Input B (internal) - '512'
 Input C (internal) - '1024'
 Input D (internal) - '2048'

Last Fault Code - Displays decimal code of the last fault. Refer to application manual for complete listing of codes.

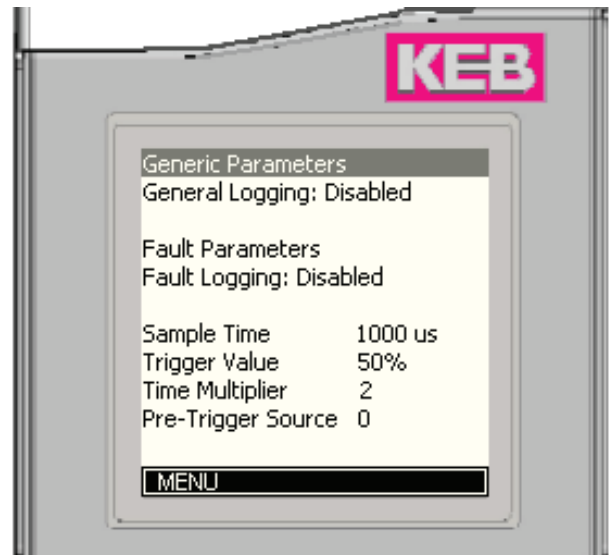

A. Appendix A

Generic Parameter Menu

Up to 10 parameters may be selected for General Logging. To change a parameter, move the cursor over the slot and hit 'Enter'. This will take you to the 'Group Menu'. To remove a parameter from the list, highlight the parameter name and hit F3 (delete). Hitting ESC will back out to the 'Data Logging Menu'. The first parameter cannot be removed.

Fault Parameter Menu

Up to 4 parameters may be selected for Fault Logging. To change a parameter, move the cursor over the slot and hit ENTER. This will take you to the 'Group Menu'. To remove a parameter from the list, highlight the parameter name and hit F3 (delete). Hitting ESC will back out to the 'Data Logging Menu'. The first parameter cannot be removed.

Group Menu

To select a parameter group, move the cursor over the desired group's name and hit ENTER. From here you can go in and select the individual parameter. Hitting ESC will back out to the previous menu.

Parameter Menu

To select a parameter for logging, move the cursor over the desired parameter's value and hit ENTER. Once a parameter is selected, the user will be returned to either the 'General Parameter Menu' or the 'Fault Parameter Menu'. Hitting ESC instead backs out to the 'Group Menu'.

2 - Recording Data

Once General and/or Fault logging is enabled, the user has selected the parameters and there is an SD card installed, the keypad is ready to begin taking data. It does not matter which screen the keypad is left at and can be returned to CP mode for real-time monitoring. Leave until ready to collect data.

Warning Message

When the SD card is in use a message will display saying 'SD card in use do not remove or turn off power' or 'Fault Logging in process do not remove SD card or turn off power'. The message will go away if any action is taken by the user or if another system message needs to be displayed. In this case an icon will appear in the lower right hand corner of the display to notify the user that the SD card is still in use. When the SD card is no longer in use, both the message and icon will go away. There is also a message to indicate the SD card memory is full, 'Memory Full, Insert SD card or remove files'.

3 - Retrieving Data

Once data has been collected and is ready to analyze, the user must wait an hour before removing the SD card or powering down. This allows all temporary files to be written down to the SD card. Do not remove SD card or turn off power before this, as data will be lost. Once the SD card is removed, files can be accessed on a computer. Remember to turn off logging functions. Parameters will not be erased.

4 - Analyzing Data

General Logging files are stored as .txt files and Fault Logging files are stored as .XML's. The text files can be converted to .CSV (Comma Separated Value) to be viewed in Excel. Data is stored as raw data, so scaling may be necessary for some parameters. The fault files are scope traces which can be viewed in Combivis 6 for further analyzing.

Common Parameters for Logging:

ID	Name	ID	Name	ID	Name
ru00	Inverter State	ru10	AC Current L3	ru19	DC Bus Voltage
ru03	Actual Line Frequency	ru11	Input Voltage		
ru08	AC Current L1	ru15	DC Current		
ru09	AC Current L2	ru17	AC Current		

Note: CP parameters cannot be logged. You must instead choose the corresponding background parameters. Please contact KEB America with any further questions.

A.2 Certification

A.2.1 CE Marking

CE marked power supply and regenerative units were developed and manufactured to comply with the regulations of the Low-Voltage Directive 2014/35/EU.

The described units must not be started until it is determined that the installation complies with the Machine directive (2006/42/EC) as well as the EMC-directive (2014/30/EU)(note EN 60204).

The power supply and regenerative units meet the requirements of the Low-Voltage Directive 2014/35/EU. The harmonized standards of the series EN 61800-5-1 in connection with EN 60439-1 and EN 60146 were used.

This is a product of limited availability in accordance with IEC 61800-3. This product may cause radio interference in residential areas. In this case the operator may need to take corresponding measures.

A.2.2 UL Certification

	<p>Acceptance according to UL is marked at KEB power supply and regenerative units with the adjacent logo on the type plate.</p>
---	--

To be conform according to UL for the use on the North American Market the following instructions must be observed (original text of the UL file in English):

- Maximum surrounding air temperature 45°C
- Suitable for use on a circuit capable of delivering not more than 100kA rms symmetrical amperes, 480 volts maximum, and when protected by fuses as listed below:

Feedback unit Cat. No.	Fuse
25.R6 (400 / 480V)	Type HSJ300 mfr. by Ferraz Shawmut, rated 300A/600Vac, high speed, UL listed NDB6-26

- Use 75°C copper conductors only
- Use in a pollution degree 2 environment
- Writing terminals are marked to show a range of values or a nominal value of tightening torque in pound-inches to be applied to the clamping screws as shown below:
- Mains terminals of all 25.R6 units: 175 lb-in (20Nm)



KEB Automation KG.

Försterweg 36-38 • D-32683 Barntrup
fon: +49 5263 401-0 • fax: +49 5263 401-116
net: www.keb.de • mail: info@keb.de

KEB worldwide...

KEB Automation GmbH

Ritzstraße 8 • 4614 Marchtrenk
fon: +43 7243 53586-0 • fax: +43 7243 53586-21
net: www.keb.at • mail: info@keb.at

KEB Automation KG

Herenveld 2 • 9500 Geraadsbergen
fon: +32 5443 7860 • fax: +32 5443 7898
mail: vb.belgien@keb.de

KEB Power Transmission Technology (Shanghai) Co.,Ltd.

No. 435 Qianpu Road, Chedun Town, Songjiang District,
Shanghai 201611, P.R. China
fon: +86 21 37746688 • fax: +86 21 37746600
net: www.keb.de • mail: info@keb.cn

KEB Automation GmbH

Organizační složka
Suchovrbenske nam. 2724/4 • 370 06 České Budějovice
fon: +420 387 699 111 • fax: +420 387 699 119
mail: info@keb.cz

KEB Antriebstechnik GmbH

Wildbacher Str. 5 • 08289 Schneeberg
fon: +49 3772 67-0 • fax: +49 3772 67-281
mail: info@keb-drive.de

KEB España

C/ Mitjer, Nave 8 - Pol. Ind. LA MASIA
08798 Sant Cugat Sesgarrigues (Barcelona)
fon: +34 93 897 0268 • fax: +34 93 899 2035
mail: vb.espana@keb.de

Société Française KEB

Z.I. de la Croix St. Nicolas • 14, rue Gustave Eiffel
94510 LA QUEUE EN BRIE
fon: +33 1 49620101 • fax: +33 1 45767495
net: www.keb.fr • mail: info@keb.fr

KEB (UK) Ltd.

Morris Close, Park Farm Industrial Estate
Wellingborough, NN8 6 XF
fon: +44 1933 402220 • fax: +44 1933 400724
net: www.keb.co.uk • mail: info@keb.co.uk

KEB Italia S.r.l.

Via Newton, 2 • 20019 Settimo Milanese (Milano)
fon: +39 02 3353531 • fax: +39 02 33500790
net: www.keb.de • mail: kebitalia@keb.it

KEB Japan Ltd.

15-16, 2-Chome, Takanawa Minato-ku
Tokyo 108-0074
fon: +81 33 445-8515 • fax: +81 33 445-8215
mail: info@keb.jp

KEB Korea Seoul

Room 1709, 415 Missy 2000
725 Su Seo Dong, Gang Nam Gu
135-757 Seoul/South Korea
fon: +82 2 6253 6771 • fax: +82 2 6253 6770
mail: vb.korea@keb.de

KEB America, Inc.

5100 Valley Industrial Blvd. South
Shakopee, MN 55379
fon: +1 952 224-1400 • fax: +1 952 224-1499
net: www.kebamerica.com • mail: info@kebamerica.com

More information can be found at www.kebamerica.com

KEB America Elevator Support Page:



© KEB		
Document	20214162	
Part/Version	USA	01
Date	07/2025	